

1968

TRIUMPH

**REPLACEMENT
PARTS**

CATALOGUE No. 6

UNIT CONSTRUCTION 40 cu. ins. TWINS

TR6R TROPHY SPECIAL

TR6C TROPHY SPORTS

T120R BONNEVILLE 120

From engine No. DU 66246

TRIUMPH ENGINEERING COMPANY LIMITED
MERIDEN WORKS · ALLESLEY · COVENTRY · ENGLAND
TELEPHONE MERIDEN 331 TELEGRAMS "TRUSTY COVENTRY"

PUBLISHED SEPTEMBER 1967

REF. 32/67

ILLUSTRATION INDEX

<i>Fig. No.</i>	<i>Description</i>	<i>Page No.</i>
1	CRANKSHAFT AND CONNECTING RODS	12
2	CRANKCASE	14
3	OIL PUMP, RELEASE VALVE, MANIFOLD AND TAPPETS	16
4	CYLINDER BLOCK AND HEAD, TR6C, TR6R	18
5	CYLINDER BLOCK AND HEAD, T120R	20
6	TIMING COVER AND CONTACT BREAKER	22
7	GEARBOX INNER COVER AND SELECTORS	24
8	GEARBOX SHAFTS AND GEARS	26
9	GEARBOX OUTER COVER	28
10	CLUTCH	30
11	CHAINCASE AND CHAINS	32
12	FRAME	34
13	SWINGING FORK AND SUSPENSION UNITS	36
14	ENGINE UNIT FITTINGS AND FOOTRESTS	38
15	EXHAUST PIPES AND MUFFLERS TR6R, T120R	40
16	EXHAUST PIPES AND MUFFLERS TR6C	42
17	TELESCOPIC FRONT FORK	44
18	TELESCOPIC FRONT FORK AND STEERING DAMPER TR6C	46
19	FRONT WHEEL	48
20	REAR WHEEL	50
21	GAS TANKS	52
22	OIL TANK	54
23	BATTERY CARRIER AND AIR FILTERS	56
24	PANEL AND TWINSEAT	58
25	FENDERS	60
26	HANDLEBARS AND CONTROL LEVERS	62
27	CONTROL CABLES	64
28	TOOLKIT, FRAME LOCK, PILLION FOOTRESTS AND LICENCE HOLDER	66
39	AMAL CARBURETTER TR6R, TR6C	68
30	AMAL CARBURETTER, T120R... ..	70
31	SPEEDOMETER AND TACHOMETER	72
32	IGNITION CAPACITOR AND HEADLAMP, TR6C	74
33	IGNITION COILS, HORN, RECTIFIER AND ZENER DIODE	76
34	HEADLAMP, WIRING HARNESS, SWITCHES AND TAIL LAMP	78

INDEX

	<i>Page</i>		<i>Page</i>
AIR FILTER	57	MANIFOLD	17
ALTERNATOR	13, 32	MUFFLERS	41, 43
BATTERY CARRIER	57	OIL PUMP	17
CARBURETTER	69, 71	OIL TANK	55
CARTON PACKS	8	PILLION FOOTRESTS	67
CENTRE STAND	35	PISTONS	13
CHAINCASE	35	PROP STAND	35
CHAINS	35	REAR PANEL	59
CLUTCH	31	REAR WHEEL	51
COIL	77	RECTIFIER	77
CONTACT BREAKER	23	SPARK PLUGS	77
CONTROL CABLES	65	SPEEDOMETER	73
CONTROL LEVERS	63	STEERING RACES	35
CRANKCASE	15	SUSPENSION UNITS	36
CRANKSHAFT	13	SWITCHES	75, 79
CYLINDER HEAD	19, 21	TIMING GEARS	13
ENGINE PLATES	39	TOOLKIT	67
EXHAUST PIPES	41, 43	TWINSEAT	59
FENDERS	61	VALVES	19, 21
FOOTRESTS	39	WIRING HARNESS	75, 79
FRONT FORKS	45, 47	ZENER DIODE	77
FRONT WHEEL	48		
GAS TANKS	52		
GASKET SETS	8		
GEARBOX	25, 27, 29		
HANDLEBARS	63		
HORN	77		

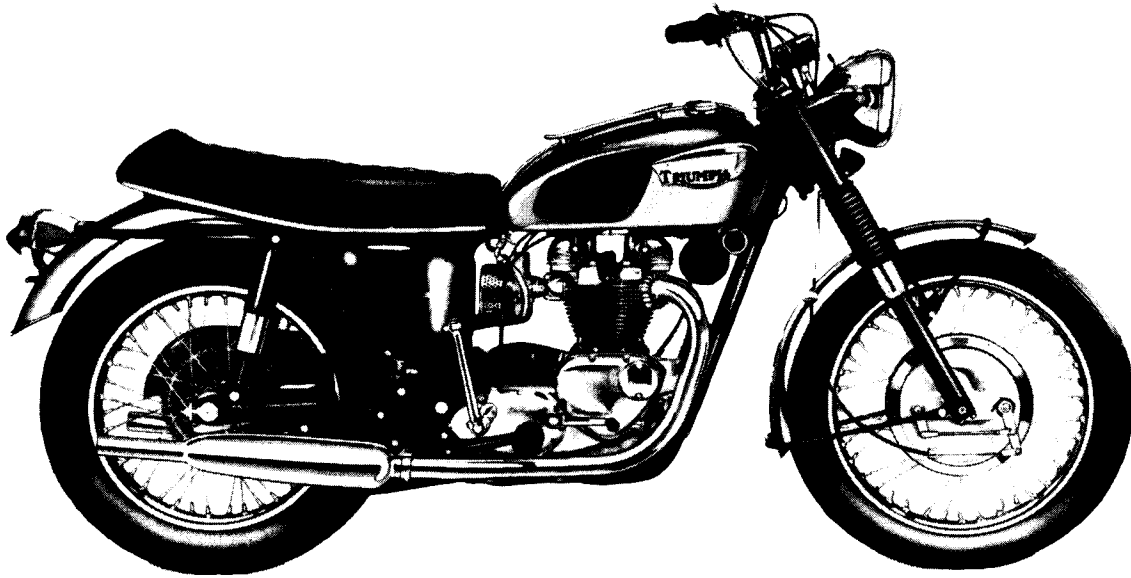

U.S.A. TROPHY (TR6R) TECHNICAL DATA

Bore and stroke...	71 x 82 mm. 2.79 x 3.23 ins.
Capacity	649 c.c. (40 cu. ins.)
Compression ratio	9 : 1
Spark plugs	Champion N3
Carburetter	Amal Concentric 930
				Main jet	230
				Needle jet107
				Throttle valve	No. 4
				Pilot jet	25
Gearbox sprocket	19 teeth
Chains	Front	$\frac{3}{8}$ " Duplex x 84 links
				Rear	$\frac{5}{8}$ " x $\frac{5}{8}$ " x 104 links
Capacities	Gas Tank	3 $\frac{3}{4}$ U.S. galls. (16 litres)
				Oil Tank	6 U.S. pints (2.8 litres)
				Gearbox	$\frac{7}{8}$ pint (500 c.c.)
				Primary Chaincase	$\frac{5}{8}$ pint (350 c.c.)
				Front Forks (each leg)	$\frac{1}{3}$ pint (200 c.c.)
Brakes	Front, diameter...	8" (20.32 cm.)
				Rear, diameter	7" (17.78 cm.)
Tire size	Front	3.25 x 19
				Rear	4.00 x 18

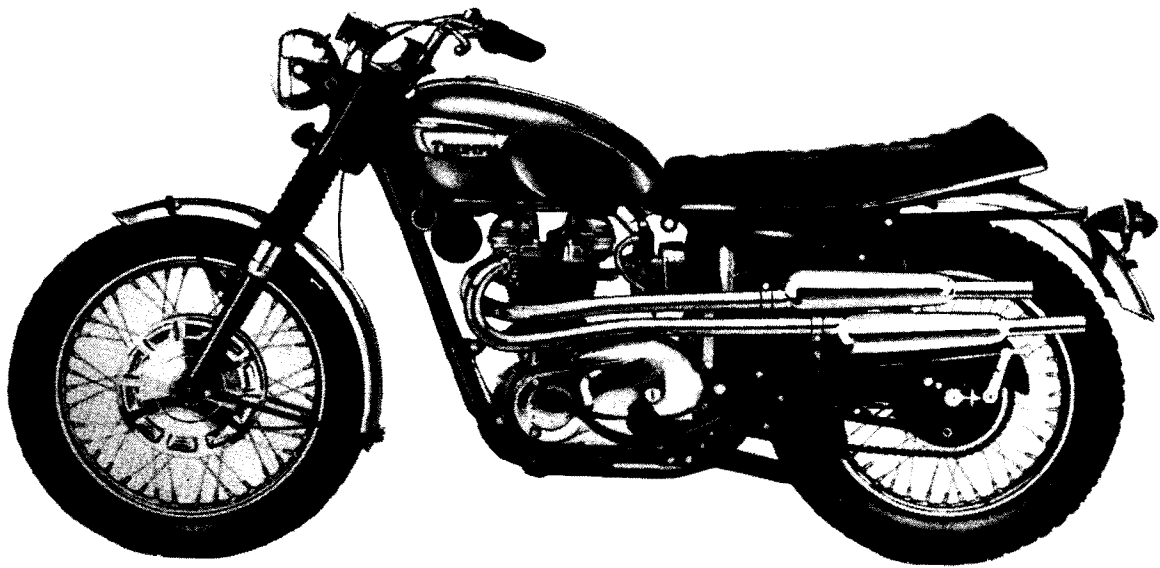

TROPHY (TR6C) TECHNICAL DATA

Bore and stroke...	71 x 82 mm. 2.79 x 3.23 ins.
Capacity	649 c.c. (40 cu. ins.)
Compression ratio	9 : 1
Spark plugs	Champion N3
Carburetter	Amal Concentric 930
										Main jet 230
										Needle jet107
										Throttle valve No. 4
										Pilot jet 25
Gearbox sprocket	18 teeth
Chains	Front $\frac{3}{8}$ " Duplex x 84 links
										Rear $\frac{5}{8}$ " x $\frac{3}{8}$ " x 104 links
Capacities	Gas Tank 2 $\frac{3}{4}$ U.S. galls. (11 litres)
										Oil Tank 6 U.S. pints (1.8 litres)
										Gearbox $\frac{7}{8}$ pint (500 c.c.)
										Primary Chaincase $\frac{5}{8}$ pint (350 c.c.)
										Front Forks (each leg) $\frac{1}{2}$ pint (200 c.c.)
Brakes	Front, diameter... .. 8" (20.32 cm.)
										Rear, diameter 7" (17.78 cm.)
Tire size	Front 3.50 x 19
										Rear 4.00 x 18

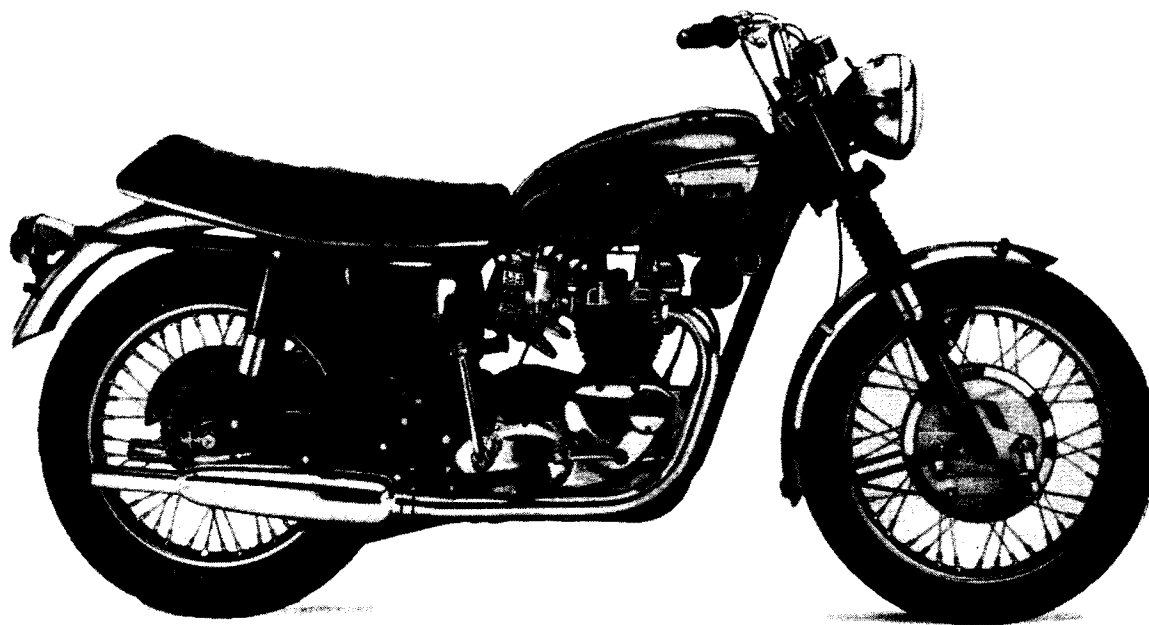

BONNEVILLE 120 (T120R) TECHNICAL DATA

Bore and stroke...	71 x 82 mm. 2.79 x 3.23 ins.
Capacity	649 c.c. (40 cu. ins.)
Compression ratio	9 : 1
Spark plugs	Champion N3
Carburetters	2 Amal Concentric 930
										Main jet 220
										Needle jet107
										Throttle valve No. 3
										Pilot jet 20
Gearbox sprocket	19 teeth
Chains	Front $\frac{3}{8}$ " Duplex x 84 links
										Rear $\frac{5}{8}$ " x $\frac{3}{8}$ " x 104 links
Capacities	Gas Tank 2 $\frac{1}{2}$ U.S. galls. (11 litres)
										Oil Tank 5 U.S. pints (2.8 litres)
										Gearbox $\frac{7}{8}$ pint (500 c.c.)
										Primary Chaincase $\frac{5}{8}$ pint (350 c.c.)
										Front Forks (each leg) $\frac{1}{3}$ pint (200 c.c.)
Brakes	Front, diameter... .. 8" (20.32 cm.)
										Rear, diameter 7" (17.78 cm.)
Tire Size	Front 3.25 x 19
										Rear 4.00 x 18

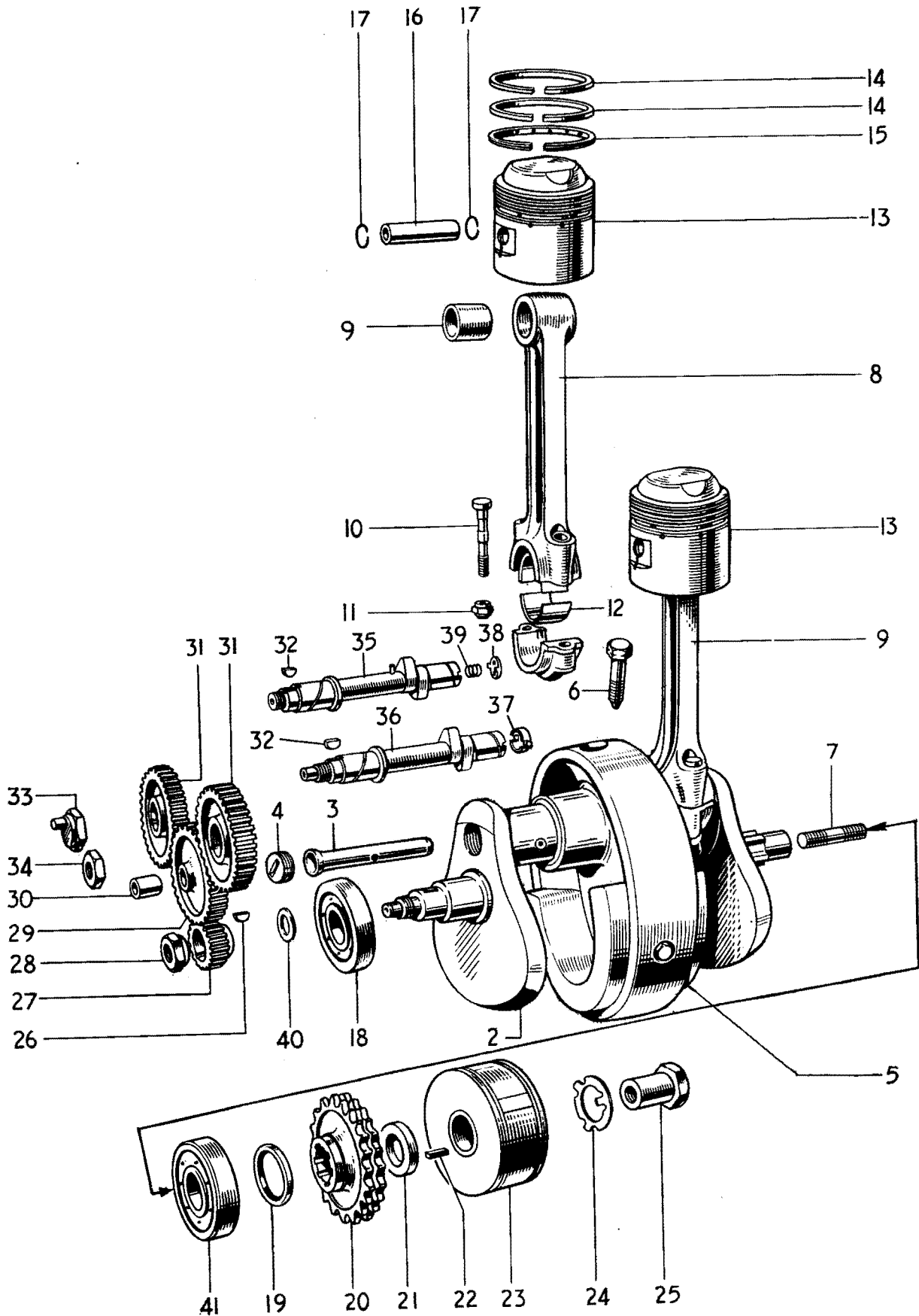

Fig. 1. CRANKSHAFT AND CONNECTING RODS

Ref. No.	Part No.	DESCRIPTION	QUANTITY	REMARKS
CRANKSHAFT AND CONNECTING RODS				
1	E7331	CRANKSHAFT AND FLYWHEEL ASSEMBLY	1	
2	E4643	CRANKSHAFT C/W. OIL TUBE	1	
3	E3903	Oil tube	1	
4	E3905	Screwed plug	1	
5	E7332	Flywheel	1	
6	*E6328	Flywheel bolt	3	
7	E3114	Crankshaft stud (1 $\frac{3}{8}$ " O.A.)	1	
8	E3606T	CONNECTING ROD	2	
9	E1511	Small end bush	2	
10	E2490A	Connecting rod bolt	4	
11	E2922	Self locking nut	4	
12	E3586	Big end bearing	4	
13	E6868	PISTON COMPLETE 9 : 1 C.R.	2	
13	E6867	PISTON COMPLETE 11 : 1 C.R.	2	
14	E6864	Taper compression ring	4	
15	E6865	Oil control ring	2	
16	E6863	Gudgeon pin (long)	2	
17	E6869	Circlip	4	
18	E1591	Main bearing, right	1	
19	E3876	Oil seal	1	
20	E5446	Engine sprocket, 29 teeth Duplex	1	
21	E4573	Distance piece	1	
22	E3974	Rotor key	1	
23	54213901	Rotor, type RM19	1	
24	E3975	Tab washer	1	
25	E3977	Nut	1	
26	E1580	Key	1	
27	E4564	Timing pinion	1	
28	E4565	Nut	1	
29	E6159	INTERMEDIATE WHEEL	1	
30	E400	Intermediate wheel bush...	1	
31	E4562	Camshaft wheel...	2	
32	E1558	Camshaft key	2	
33	E1463	Inlet camshaft nut	1	
34	E4563	Exhaust camshaft nut	1	
35	E4819	Inlet camshaft	1	
36	E5047	EXHAUST CAMSHAFT	1	
37	†E4700	Tachometer drive thimble	1	
38	E5316	Rotary breather valve	1	
39	E2256	Breather valve spring	1	
40	E3300	Clamping washer	1	
41	E2879	Main bearing, left	1	
	E4849	Dowel pin for exhaust camshaft	1	(Not illustrated)

* Use D524 Loctite Sealant

† Use E7050 to replace without dismantling motor

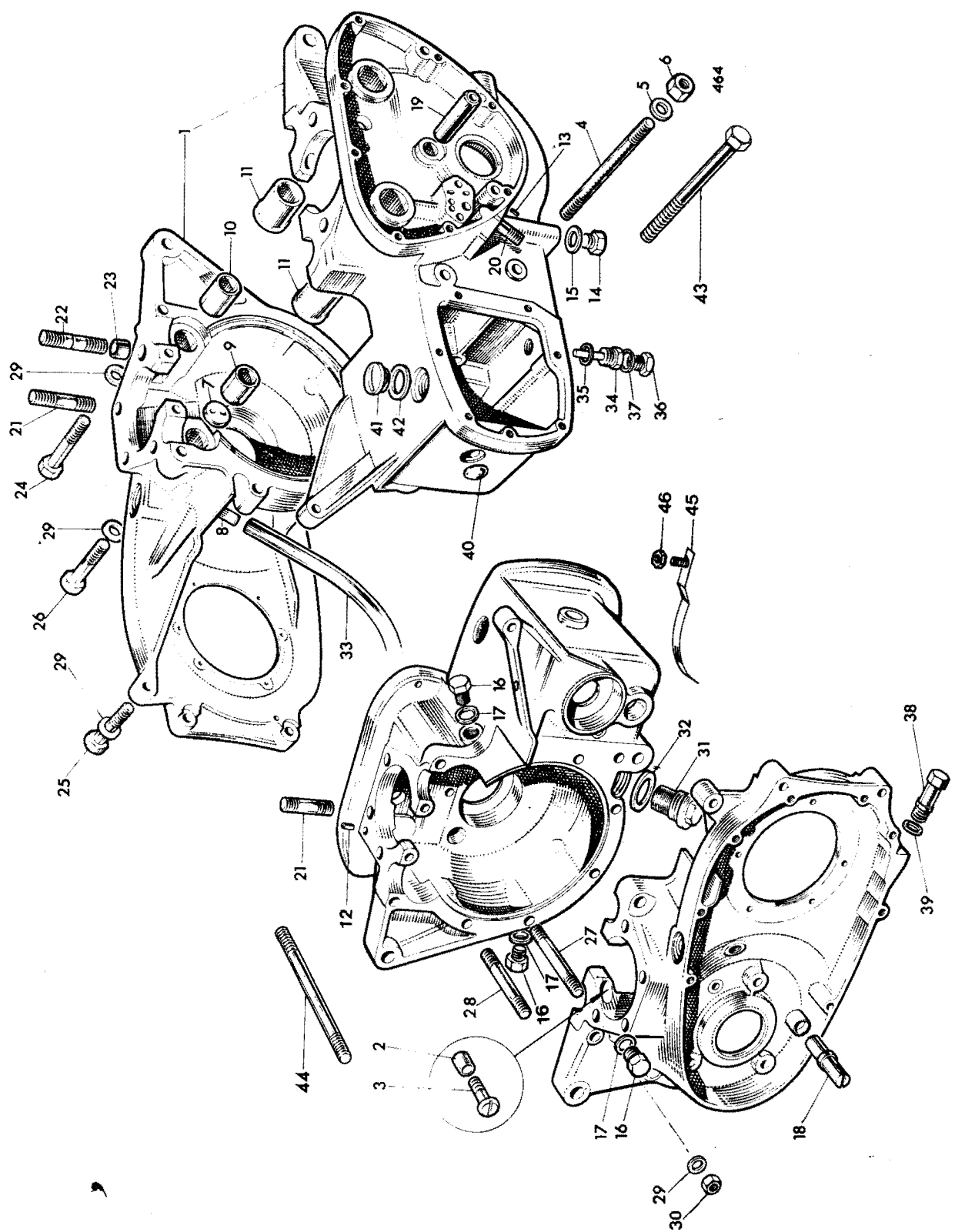

FIG. 2. CRANKCASE

Ref. No.	Part No.	DESCRIPTION	QUANTITY	REMARKS
CRANKCASE				
1	E5871/7330	CRANKCASE	1	
2	E3716	Hollow Dowel	1	
3	E5232	Screw ($\frac{21}{32}$ in. U.H.)	2	
4	E4542	Stud ($4\frac{1}{2}$ in. O.A.)	1	
5	S25-2	Plain washer	2	
6	P0172A	Nut	2	
7	GS87	Breather disc	1	
8	E2724	Breather pipe	1	
9	E2260	Inlet camshaft bush	1	
10	E1516	Exhaust camshaft bush	1	
11	E1479	Camshaft bush	2	
12	E1532	Hollow dowel, tappet oil feed	1	
13	E6386	Locating peg	1	Not serviced
14	E4539	Oilway plug	1	
15	F1880	Copper washer	1	
16	E4706	Tachometer drive plug	3	
17	E8896	Fibre washer	3	
18	E5976	Chain tensioner abutment	1	
19	E375	Intermediate wheel spindle	1	
20	E3717	Oil pipe stud ($1\frac{1}{2}$ in. O.A.)	1	
21	E672	Cylinder stud ($1\frac{5}{8}$ in. O.A.)	6	
22	E3523	Cylinder stud ($1\frac{5}{8}$ in. O.A.)	2	
23	E1534A	Hollow dowel	2	
24	E4541	Bolt ($2\frac{1}{2}$ in. U.H.)	1	
25	E4540	Bolt ($1\frac{3}{4}$ in. U.H.)	1	
26	E4098	Bolt ($1\frac{7}{8}$ in. U.H.)	1	
27	E4856	Stud ($5\frac{1}{16}$ in. O.A.)	1	
28	E2888	Stud ($3\frac{7}{8}$ in. O.A.)	2	(TR6C 3 off)
29	S25-3	Plain washer	11	
30	S1-51	Nut	8	
31	E5312	Crankcase filter... ..	1	
32	E5315	Copper washer	1	
33	E5375	Breather extension pipe	1	
34	T1112	Drain plug (with level tube)	1	
35	T1257	Fibre washer	1	
36	T361	Level plug	1	
37	E2441	Copper washer	1	
38	E6347	Drain and adjuster plug	1	
39	T1738	Fibre washer	1	
40	T1920	Blanking plug	1	
41	E732	Filler plug	2	
42	NE507	Fibre washer	2	
43	E6929	Bolt (4 in. U.H.)	1	
44	E5963	Stud ($4\frac{3}{4}$ in. O.A.)	1	(except TR6C)
45	E8892	Protection blade	1	
46		Self lock nut	1	

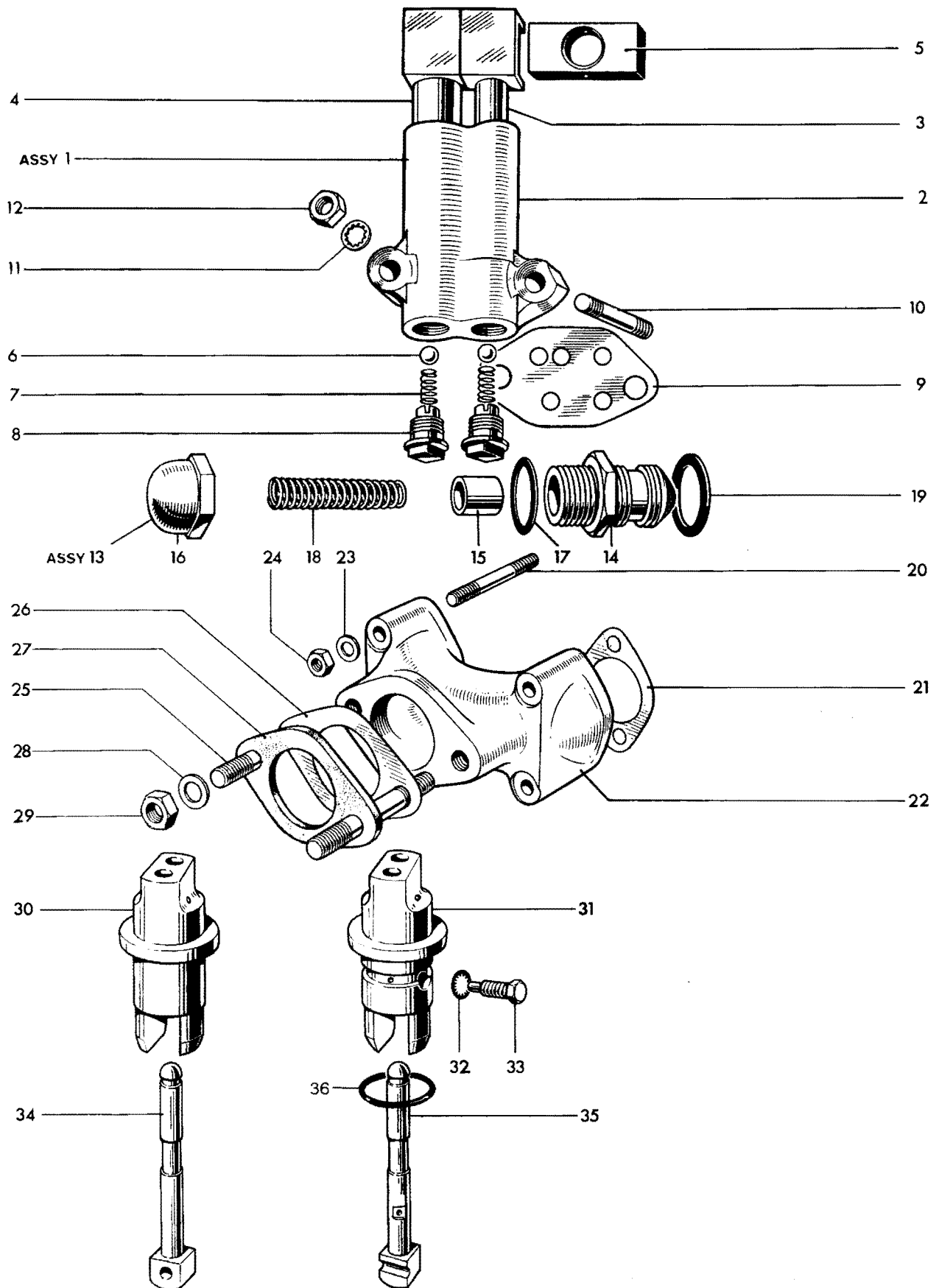

Fig. 3. OIL PUMP, RELEASE VALVE, MANIFOLD AND TAPPETS

OIL PUMP, RELEASE VALVE, MANIFOLD AND TAPPETS

1	E6928	OIL PUMP	1	
2	E6680	Pump body...	1	
3	GS153	Feed plunger	1	
4	E6681	Scavenge plunger	1	
5	E495	Drive block	1	
6	S70-7	Valve ball ($\frac{7}{32}$ in. dia.)	2	
7	E403	Valve spring	2	
8	E2360	Screwed plug	2	
9	E3730	Joint washer	1	
10	E3718	Oil pump stud ($1\frac{5}{16}$ in. U.H.)	2	
11	E3887	Serrated washer	2	
12	E3732	Nut	2	
13	E5896	OIL RELEASE VALVE	1	
14	E2794	Valve body	1	
15	GS251	Piston	1	
16	E2304	Cap	1	
17	GS254	Fibre washer	1	
18	E6062	Main spring	1	
19	E1670	Fibre washer	1	
20	E2973	Stud ($1\frac{5}{8}$ in. O.A.)	4	
21	E5660	Joint washer	2	} TR6R & TR6C
22	E5512	Inlet manifold	1	
23	S25-13	Plain washer	4	
24	W103	Nut	4	
25	E2962	Stud ($1\frac{7}{32}$ in. O.A.)	2	
26	NA43A	Joint washer	1	
27	E4918	Insulating block	1	
28	S25-3	Plain washer	2	
29	E1310	Nut	2	
30	E4676	Inlet tappet guide	1	
31	E5861	Exhaust tappet guide	1	
32	E1612	Serrated washer	2	
33	H200	Set bolt	2	
34	E3059R	Inlet tappet	2	
35	E8801	Exhaust tappet	2	
36	E7563	"O" ring	2	

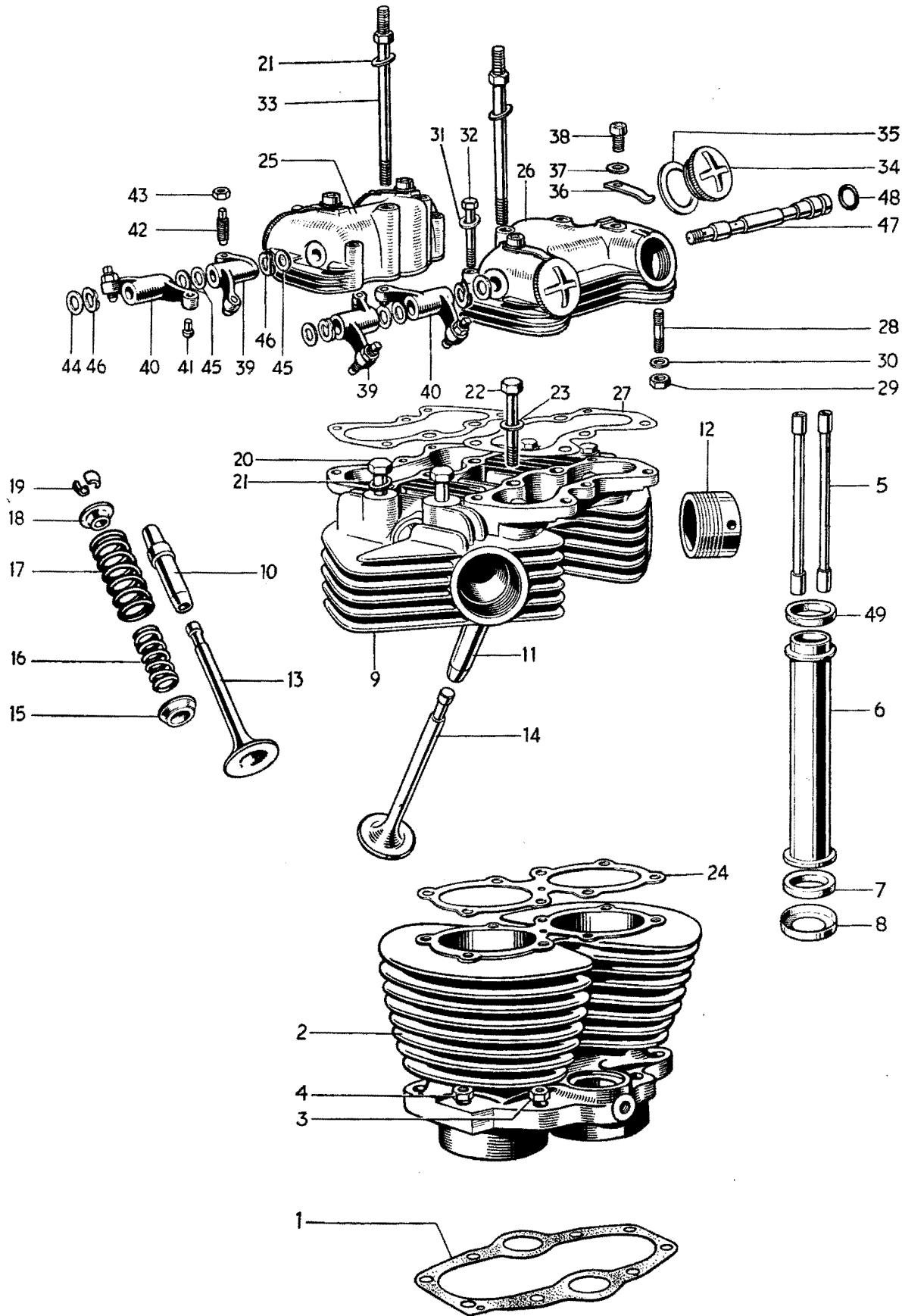

Fig. 4. CYLINDER BLOCK AND HEAD, TR6

CYLINDER BLOCK AND HEAD, TR6R, TR6C

1	E6309	Cylinder base washer	1	
2	E6304	Cylinder block	1	
3	W76	Inner cylinder base nut	4	
4	P0172A	Outer cylinder base nut	4	
5	E2620	Push rod	4	
6	E6000	Cover tube	2	
7	E4752	Rubber washer	2	
8	E4746	Bottom cup	2	
9	E7031	CYLINDER HEAD c/w GUIDES	1	
10	E2899	Inlet valve guide	2	
11	E2900	Exhaust valve guide	2	
12	E3583	Exhaust pipe adaptor	2	
13	E4603	Inlet valve	2	
14	E2904	Exhaust valve	2	
15	E6439	Bottom cup	4	
16	E4221	Inner valve spring (red spot)	4	
17	E7400	Outer valve spring (green spot)	4	
18	E1543	Top collar	4	
19	WE259A	Split cotter	8	
20	E327	Cylinder head bolt (3 $\frac{1}{8}$ in. U.H.)	4	
21	F2184	Plain washer	8	
22	E4771	Bolt (3 in. U.H.)	1	
23	S25-3	Plain washer	1	
24	E4547	Cylinder head gasket	1	
25	E4550	Inlet rocker box	1	
26	E4551	Exhaust rocker box	1	
27	E4549	Joint washer	2	
28	E2980	Rocker box stud (1 $\frac{1}{8}$ in. O.A.)	6	
29	F879	Rocker box nut... ..	6	
30	E3302	Plain washer	6	
31	E2982	Rocker box bolt (2 $\frac{1}{2}$ in. U.H.)	4	
32	S25-13	Plain washer	4	
33	E1596	Cylinder head bolt (for torque stay)	4	
34	E4610	Inspection cap	4	
35	E3751	Joint washer	4	
36	E4609	Locking spring	4	
37	WE170	Fibre washer	4	
38	T1553	Screw ($\frac{3}{8}$ in. U.H.)	4	
39	E1457	ROCKER (right exhaust, left inlet)	2	
40	E1458	ROCKER (left exhaust, right inlet)	2	
41	E1483	Rocker ball pin	4	
42	E1513	Rocker adjusting pin	4	
43	E470	Adjuster lock nut	4	
44	E1330	Thrust washer, $\frac{3}{8}$ in.	2	
45	E1575	Thrust washer, $\frac{1}{2}$ in.	6	
46	E1574	Spring washer	4	
47	E1512	Rocker spindle	2	
48	E3253	Sealing rubber	2	
49	E3547	Rubber washer	2	

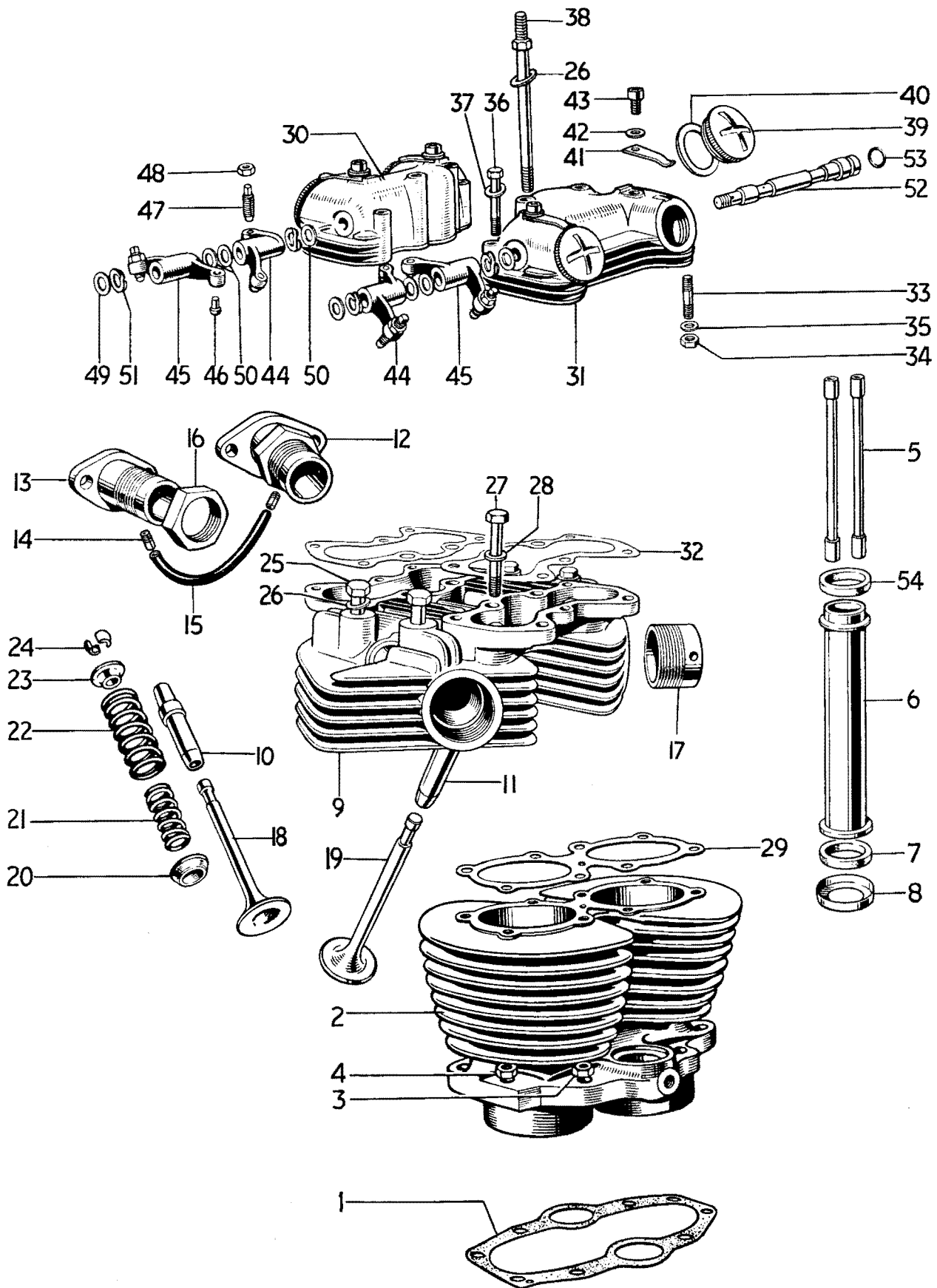

Fig. 5. CYLINDER BLOCK AND HEAD, T120R

Ref. No.	Part No.	DESCRIPTION	QUANTITY	REMARKS
CYLINDER BLOCK AND HEAD, T120R				
1	E6309	Cylinder base washer	1	
2	E6304	Cylinder block	1	
3	W76	Inner cylinder base nut	4	
4	P0172A	Outer cylinder base nut	4	
5	E2620	Push rod	4	
6	E6000	Cover tube	2	
7	E4752	Rubber washer	2	
8	E4746	Bottom cup	2	
9	E5727	CYLINDER HEAD c/w GUIDES	1	
—	E5347	Sleeve for head bolts passing through inlet tracts	2	(Not illustrated)
10	E3827	Inlet valve guide	2	
11	E3828	Exhaust valve guide	2	
12	E5351	Carburetter adaptor, left	1	
13	E5352	Carburetter adaptor, right	1	
14	E4791	Connector	2	
15	E4792	Balance pipe	1	
16	E4608	Adaptor locking nut	2	
17	E5914	Exhaust pipe adaptor	2	
18	E4603	Inlet valve	2	
19	E2904	Exhaust valve	2	
20	E6439	Bottom cup	4	
21	E4221	Inner valve spring (Red spot)	4	
22	E7400	Outer valve spring (green spot)	4	
23	E1543	Top collar	4	
24	WE259A	Split cotter	8	
25	E327	Cylinder head bolt (3 $\frac{3}{8}$ in. U.H.)	4	
26	F2184	Plain washer	8	
27	E4771	Bolt (3 in. U.H.)	1	
28	S25-3	Plain washer	1	
29	E4547	Cylinder head gasket	1	
30	E4550	Inlet rocker box	1	
31	E4551	Exhaust rocker box	1	
32	E4549	Joint washer	2	
33	E2980	Rocker box stud ($\frac{15}{16}$ in. O.A.)	6	
34	F879	Nut	6	
35	E3302	Plain washer	6	
36	E2982	Rocker box bolt (2 $\frac{5}{16}$ in. U.H.)	4	
37	S25-13	Plain washer	4	
38	E1596	Cylinder head bolt (for torque stay)	4	
39	E4610	Inspection cap	4	
40	E3751	Joint washer	4	
41	E4609	Locking spring	4	
42	WE170	Fibre washer	4	
43	T1553	Screw ($\frac{3}{8}$ in. U.H.)	4	
44	E1457	ROCKER (right exhaust, left inlet)	2	
45	E1458	ROCKER (left exhaust, right inlet)	2	
46	E1483	Rocker ball pin	4	
47	E1513	Rocker adjusting pin	4	
48	E470	Adjuster lock nut	4	
49	E1330	Thrust washer, $\frac{3}{8}$ in.	2	
50	E1575	Thrust washer, $\frac{1}{2}$ in.	6	
51	E1574	Spring washer	4	
52	E1512	Rocker spindle	2	
53	E3253	Sealing rubber	2	
54	E3547	Rubber washer	2	

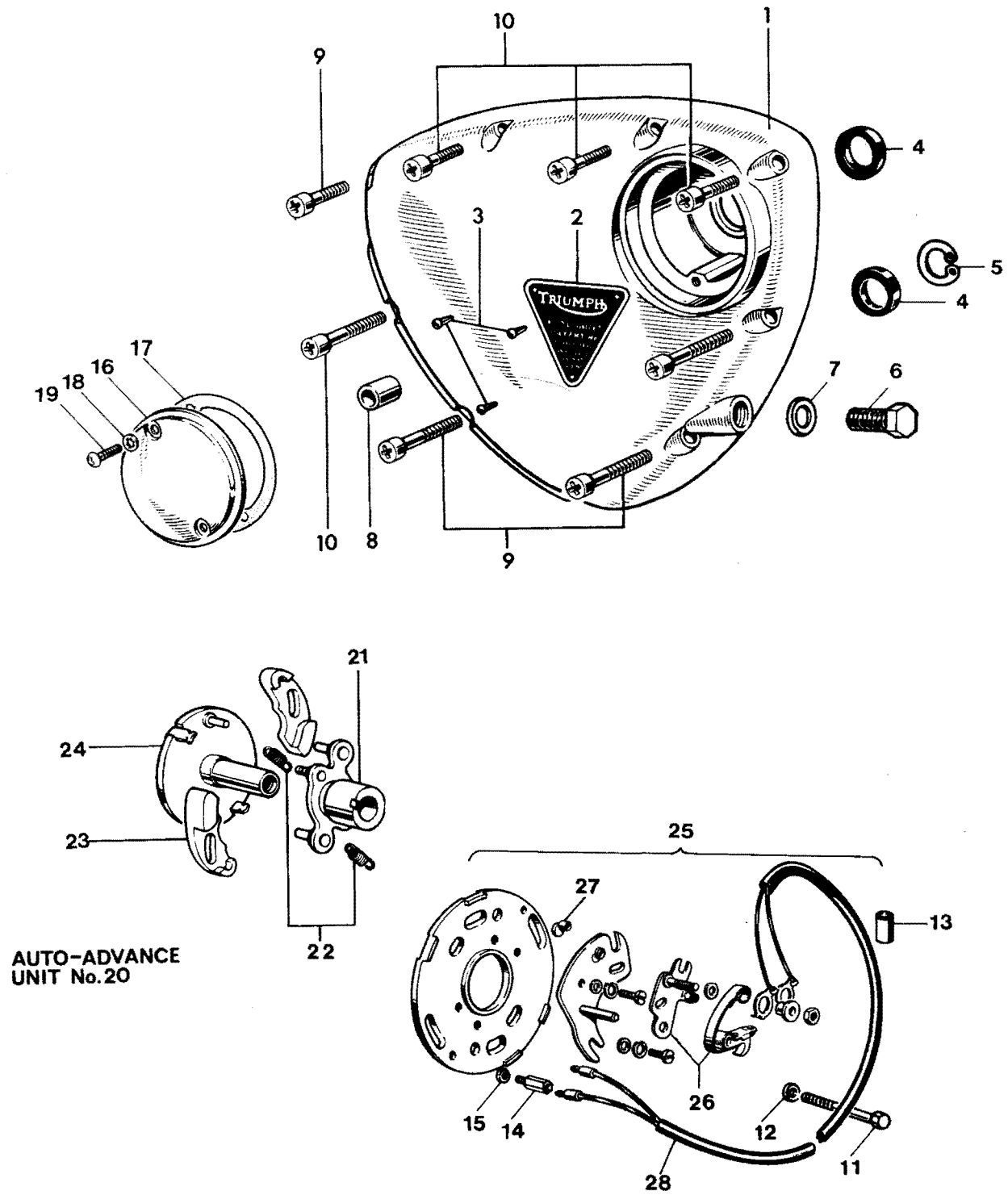

Fig. 6. TIMING COVER AND CONTACT BREAKER

TIMING COVER AND CONTACT BREAKER

1	E8797	Timing cover	1	
2	E4016	Patent plate	1	
3	D208-5	Hammer-drive screw	3	
4	E4568	Oil seal	2	
4	E6387	Oil seal (0.020 in. undersize)		For reground crankshaft
5	E4569	Circlip	1	
6	E2615	Timing cover plug	1	
7	E1335	Copper washer	1	
8	T989	Hollow dowel	1	
9	E3668	Screw (1 $\frac{5}{8}$ in. U.H.)	3	
10	E3204	Screw (1 in. U.H.)	5	
11	E8828	Bolt (2 in. U.H.)	1	
12	S25-43	Plain washer	1	
13	E4707	Rubber grommet	1	
14	E7680	Pillar bolt	2	
15	E6559	Plain washer	2	
16	E8737	Cover	1	
17	E5049	Joint washer	1	
18	GS299	Serrated washer	2	
19	F7354	Screw ($\frac{1}{2}$ in. U.H.)	2	
20	54419340	AUTO ADVANCE UNIT	1	
21	54419338	Cam	1	
22	54415642	Spring set	1	
23	42539	Weight	2	
24	54419428	Sleeve and action plate	1	
25	54419097	CONTACT BREAKER PLATE ASSEMBLY	1	
26	54419827	Contact set	2	
27	54419220	Pin, adjustment	2	
28	54933228	Lead, contact set to coil	1	

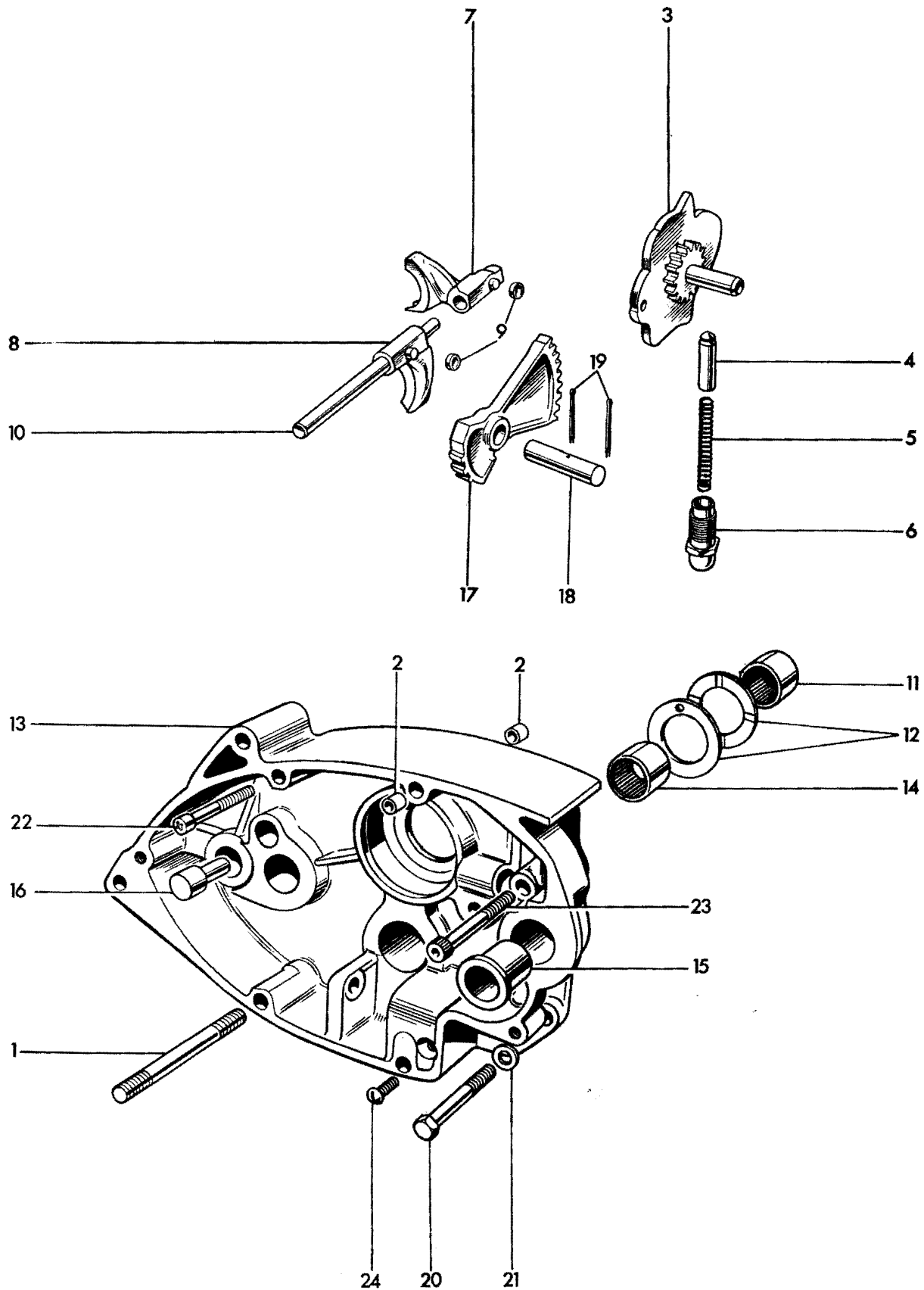

Fig. 7. GEARBOX INNER COVER AND SELECTORS

GEARBOX INNER COVER AND SELECTORS

1	E4535	Stud (3 in. O.A.)	2	
2	T989	Hollow dowel	4	
3	T3650	Gear selector camplate	1	
4	T44	Camplate index plunger	1	
5	T373	Index plunger spring	1	
5	T1604	Strong index plunger spring	as required	
6	T372	Index plunger holder	1	
7	T260B	Mainshaft selector fork	1	
8	T913	Layshaft selector fork	1	
9	NT261	Selector fork roller	2	
10	T291	Selector fork rod	1	
11	T1606	Layshaft bearing	1	
12	T1607	Thrust washer	2	
13	T2112	GEARBOX INNER COVER	1	
14	T1614	Layshaft bearing	1	
15	T412	Gearchange spindle bush...	1	
16	T45	Kickstarter stop	1	
17	T397	Camplate operating quadrant...	1	
18	T1896	Quadrant spindle	1	
19	$\frac{5}{64}$ in. x $1\frac{1}{8}$ in.	Split pin	2	
20	T1778	Bolt ($1\frac{1}{8}$ in. U.H.)	1	
21	E3446	Plain washer	1	
22	E3204	Screw (1 in. U.H.)	1	
23	T1779	Socket screw ($1\frac{3}{4}$ in. U.H.)	1	
24	E3728	Countersunk screw ($\frac{1}{2}$ in. U.H.)	1	

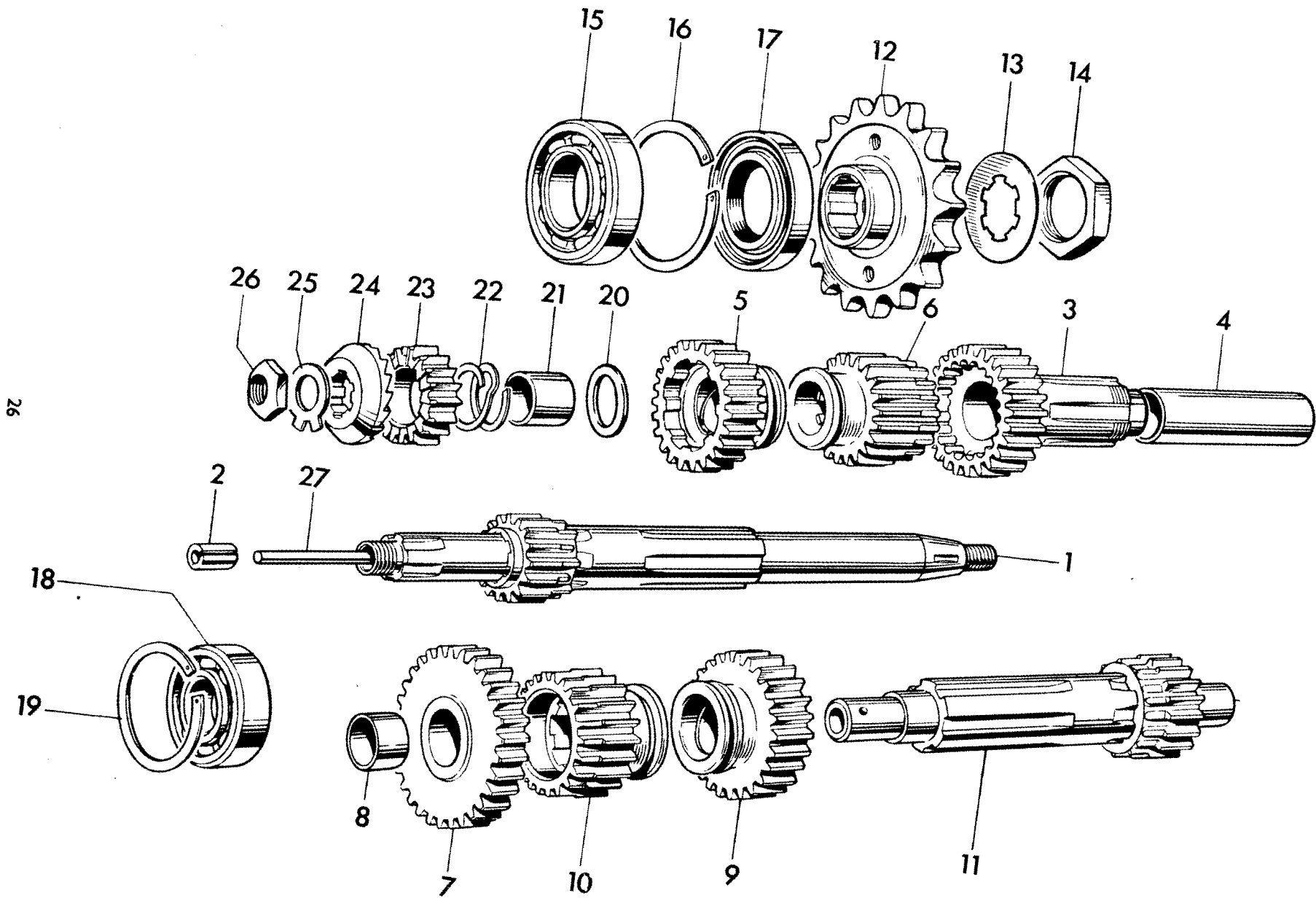

Fig. 8. GEARBOX SHAFTS AND GEARS

GEARBOX SHAFTS AND GEARS

1	T2436	MAINSHAFT c/w LOW GEAR (16T)	1	
2	PT108B	Clutch rod bush	1	
3	T2316	MAINSHAFT HIGH GEAR (26T)	1	
4	T1370	High gear bush	1	
5	T917	Mainshaft third gear (24T)	1	
6	T916	Mainshaft second gear (20T)	1	
7	T926	LAYSHAFT LOW GEAR (30T)	1	
8	T928	Low gear bush	1	
9	T1065	Layshaft second gear (26T)	1	
10	T930	Layshaft third gear (22T)	1	
11	T2093	Layshaft c/w high gear (20T)	1	
12	T1952	Gearbox sprocket (15 teeth)	1	
12	T1953	Gearbox sprocket (16 teeth)	1	
12	T1916	Gearbox sprocket (17 teeth)	1	} See pages 5 to 8 for standard sizes
12	T1917	Gearbox sprocket (18 teeth)	1	
12	T1918	Gearbox sprocket (19 teeth)	1	
12	T1919	Gearbox sprocket (20 teeth)	1	
13	T2116	Tab washer	1	
14	T440	Gearbox sprocket nut	1	
15	T448	High gear bearing	1	
16	E489	Circlip	1	
17	T946	Oil seal	1	
18	S35-7	Mainshaft bearing	1	
19	T280	Circlip	1	
20	T1962	Plain washer	1	
21	T1963	Pinion sleeve	1	
22	T1250	Pinion spring	1	
23	T730	Kickstarter pinion	1	
24	T731	Kickstarter ratchet	1	
25	T2240	Tab washer	1	
26	S594	Nut	1	
27	T1736	Clutch operating rod	1	

WIDE RATIO GEARS

3	T1912	MAINSHAFT HIGH GEAR (28T)	1	
6	T968	Mainshaft second gear (19T)	1	
9	T974	Layshaft second gear (27T)	1	
11	T1844	Layshaft c/w high gear (18T)	1	

CLOSE RATIO GEARS

1	T2438	MAINSHAFT c/w LOW GEAR (18T)	1	
3	T1910	MAINSHAFT HIGH GEAR (24T)	1	
5	T1179	Mainshaft third gear (23T)	1	
6	T955	Mainshaft second gear (21T)	1	
7	T961	LAYSHAFT LOW GEAR (28T)	1	
9	T963	Layshaft second gear (25T)	1	
10	T964	Layshaft third gear (23T)	1	
11	T1846	Layshaft c/w high gear (22T)	1	

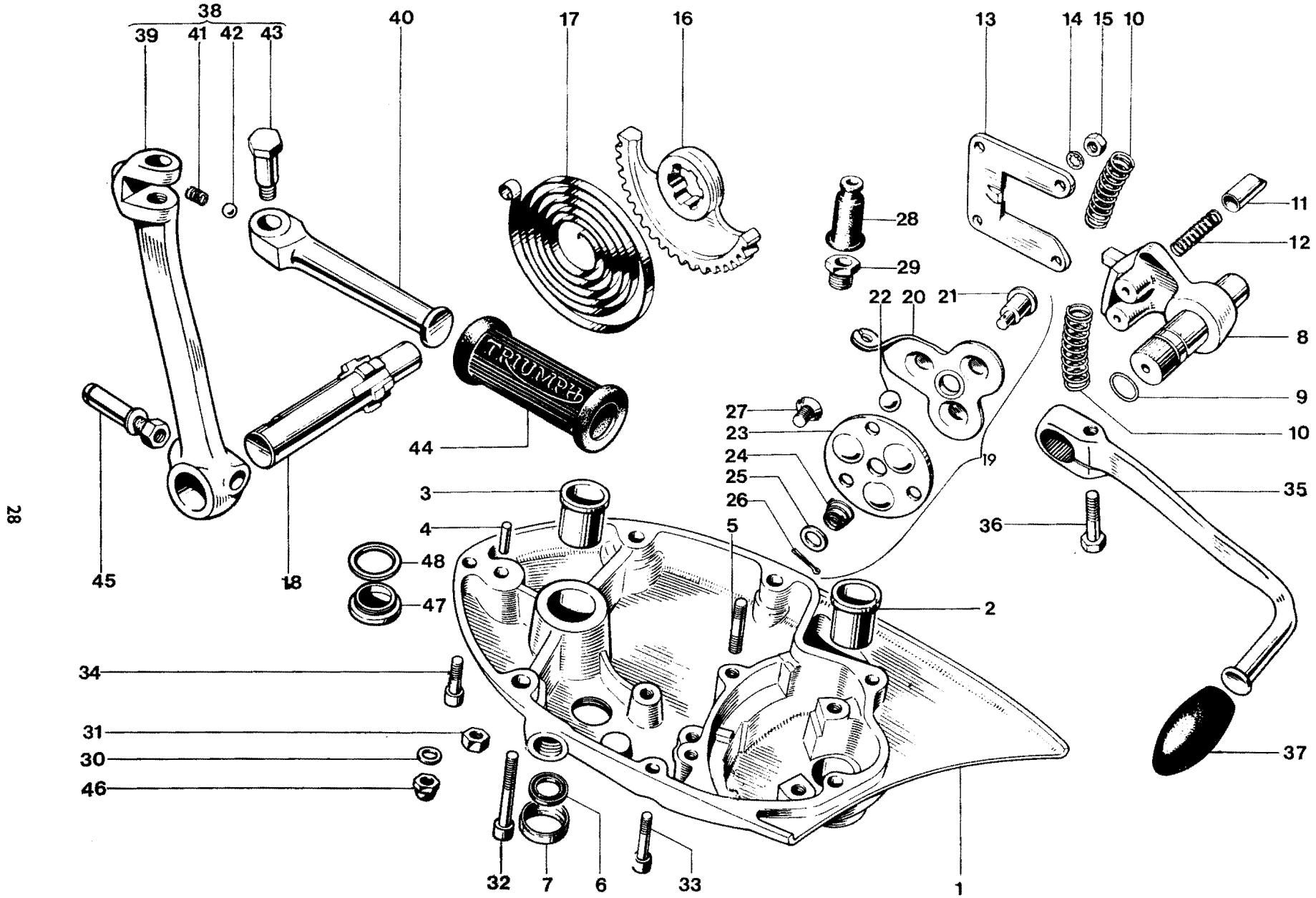

Fig. 9. GEARBOX OUTER COVER

Ref. No.	Part No.	DESCRIPTION	QUANTITY	REMARKS
GEARBOX OUTER COVER				
1	T3628	GEARBOX OUTER COVER	1	
2	T57	Gearchange spindle bush...	1	
3	T23	Kickstarter spindle bush	1	
4	T47	Kickstarter spring anchor pin	1	
5	T454	Guide plate stud ($\frac{7}{8}$ in. O.A.)	4	
6	T1956	Oil seal	1	
7	T1955	Oil seal housing	1	
8	T408/9	Gearchange quadrant	1	
9	E3309	Rubber "O" ring	1	
10	T404	Quadrant return spring	2	
11	T406	Gearchange quadrant plunger	2	
12	T405	Plunger spring	2	
13	T407	Guide plate	1	
14	E1612	Serrated washer	4	
15	F879	Nut	4	
16	T25A	Kickstarter quadrant	1	
17	T31	Kickstarter return spring	1	
18	T24A	Kickstarter axle	1	
19	T3629	CLUTCH LEVER ASSEMBLY	1	
20	T2191	Clutch lever	1	
21	T1710	Lever shaft	1	
22	T1771	Ball, $\frac{3}{8}$ in. diam.	3	
23	T1711	Thrust plate	1	
24	T1712	Return spring	1	
25	GS127	Plain washer	1	
26	$\frac{5}{64}$ in. x $\frac{1}{2}$ in.	Split pin	1	
27	T2525	Countersunk screw ($\frac{3}{8}$ in. O.A.)	2	
28	T1646	Rubber cover	1	
29	T2540	Abutment for clutch cable	1	
30	S25-3	Plain washer	2	
31	S1-51	Nut	1	
32	E3802	Screw ($2\frac{3}{4}$ in. U.H.)	2	
33	E3668	Screw ($1\frac{5}{16}$ in. U.H.)	2	
34	E3204	Screw (1 in. U.H.)	1	
35	T1750	Gearchange pedal	1	
36	W932	Bolt (1 in. U.H.)	1	
37	T2450	Pedal rubber	1	
38	T2113	FOLDING KICKSTARTER	1	
39	T2095	Kickstarter lever	2	
40	T1272	Kickstarter pedal	1	
41	T1167	Pedal locating spring	1	
42	S70-3	Steel ball, $\frac{1}{4}$ in. diam.	1	
43	T1273	Pedal bolt	1	
44	T2330	Pedal rubber	1	
45	T1222	Cotter pin c/w nut and washer	1	
46	H1531	Domed nut	1	
47	E732	Filler plug	1	
48	NE507	Fibre washer	1	

CLUTCH ASSEMBLY N° 1

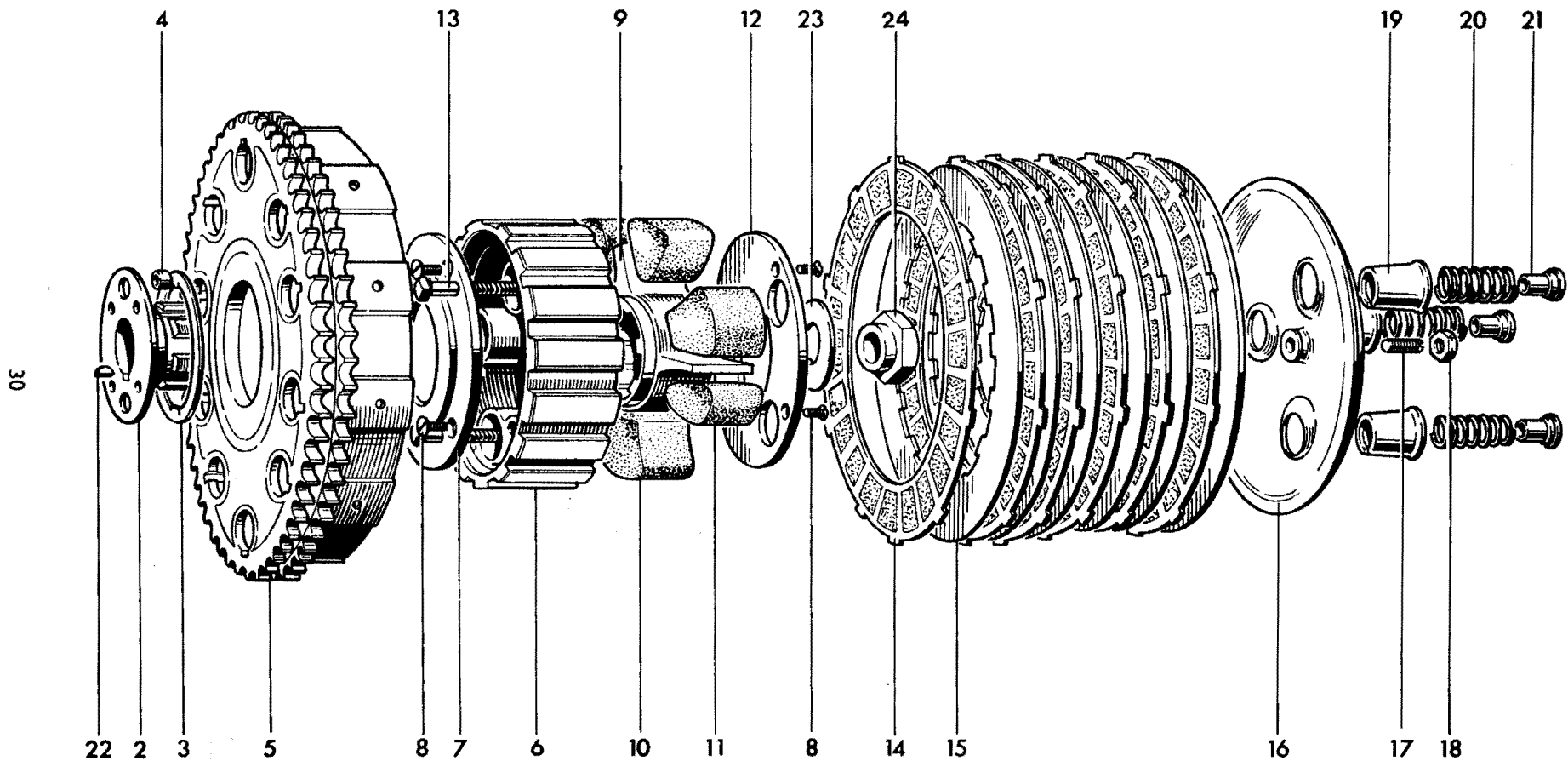

Fig. 10. CLUTCH

CLUTCH

1	T1928	CLUTCH COMPLETE	1	
2	T1734	Hub	1	
3	T1735	Thrust washer	1	
4	T394	Roller	20	
5	T1570	Sprocket and housing (58 teeth Duplex)	1	
6	T1719	Centre	1	
7	T1720	Inner plate	1	
8	T1040	Countersunk screw (0.417 in. U.H.)	6	
9	T2538	Shock absorber spider	1	
10	T1722	Drive rubber (large)	3	
11	T1723	Rebound rubber (small)	3	
12	T1724	Outer plate	1	
13	T423A	Screwed pin ($1\frac{1}{2}$ in. U.H.)	3	
14	T1362	Driving plate (bonded)	6	
15	T1363	Driven plate	6	
16	T2156	Pressure plate	1	
17	T2159	Adjuster pin	1	
18	14-0403/000	Nut	1	
19	T1931	Spring cup	3	
20	T1830	Spring	3	
21	T2526	Pressure nut	3	
22	S66-1	Key 60 425.3	1	
23	T2279	Cupped washer	1	
24	S586	Clutch securing nut	1	

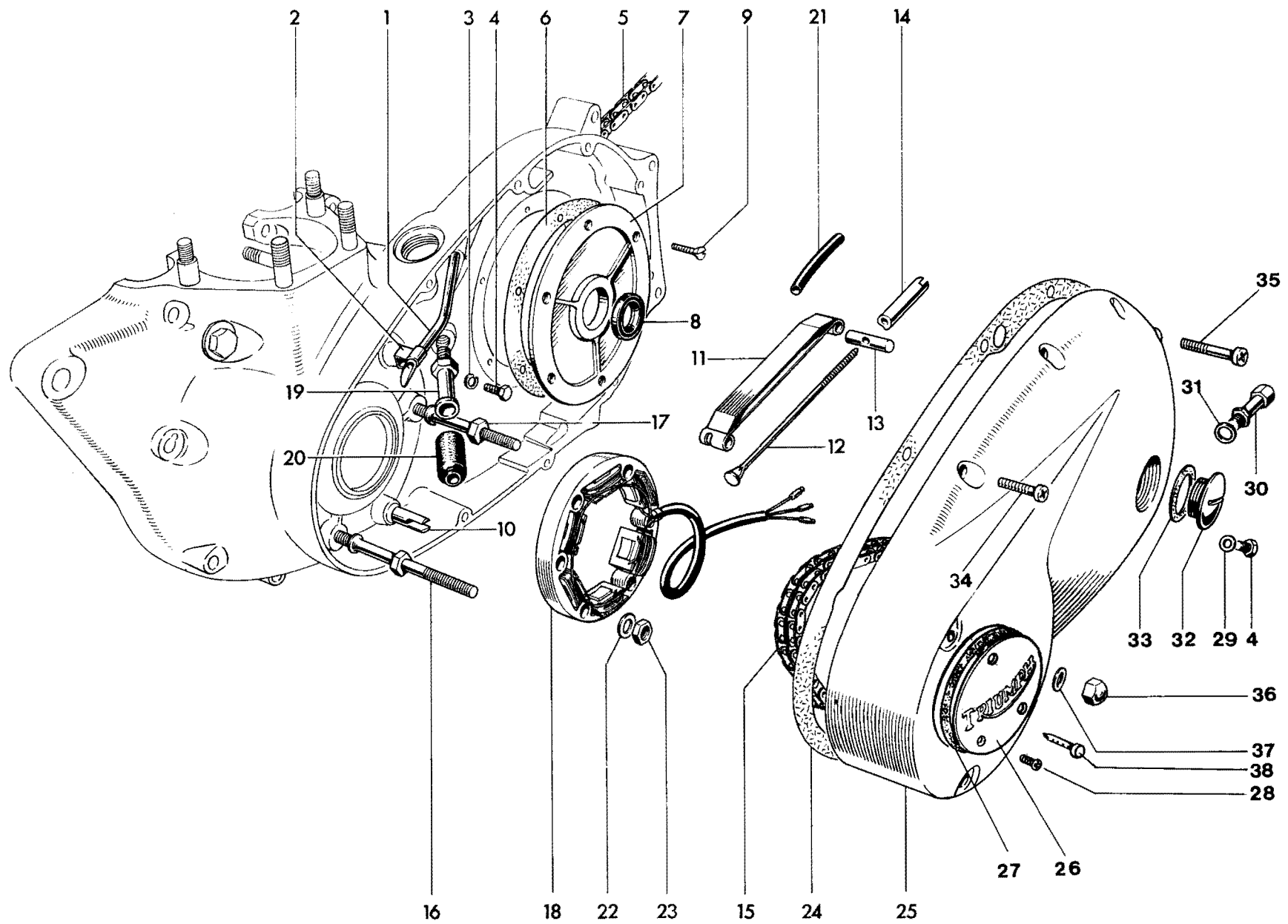

Fig. 11. CHAINCASE AND CHAINS

CHAINCASE AND CHAINS

1	E4704	Primary chain oiler tube	1	
2	E4705	Clip	1	
3	S26-2	Spring washer	1	
4	DS57	Bolt ($\frac{7}{16}$ in. U.H.)	2	
5	D530	Rear chain, $\frac{5}{8}$ in. x $\frac{3}{8}$ in. x 104 links	1	
6	E3832	Joint washer	1	
7	E7037	Cover plate	1	
8	E7565	Oil seal	1	
9	E3821	Countersunk screw ($\frac{5}{16}$ in. U.H.)	6	
10	E5976	Chain tensioner abutment	1	
11	E6061	Chain tensioner blade	1	
12	E4152	Tie rod	1	
13	E5977	Trunnion	1	
14	E4153	Adjuster sleeve nut	1	
15	D477	Primary chain, $\frac{3}{8}$ in. Duplex x 84 links	1	
16	E4536	Stator stud	2	
17	E4537	Stator stud	1	
18	47162	Stator, RM 19	1	
19	E5872	Sleeve nut	1	
20	E4144	Rubber grommet	1	
21	E5449	Plastic sleeve	1	
22	S25-3	Plain washer	3	
23	E5324	Self-locking nut	3	
24	T1770	Joint washer	1	
25	T2439	Chaincase	1	
26	T2440	Rotor cover	1	
27	T2442	Joint washer	1	
28	F4129	Screw	3	
29	E2441	Copper washer	1	
30	E6347	Drain and adjuster plug	1	
31	T1738	Fibre washer	1	
32	E732	Filler plug	1	
33	NE507	Fibre washer	1	
34	E3204	Screw (1 in. U.H.)	6	
35	E4806	Screw ($\frac{3}{8}$ in. U.H.)	2	
36	H1531	Domed nut	2	
37	F1880	Copper washer	2	
38	T2443	Timing pointer	1	

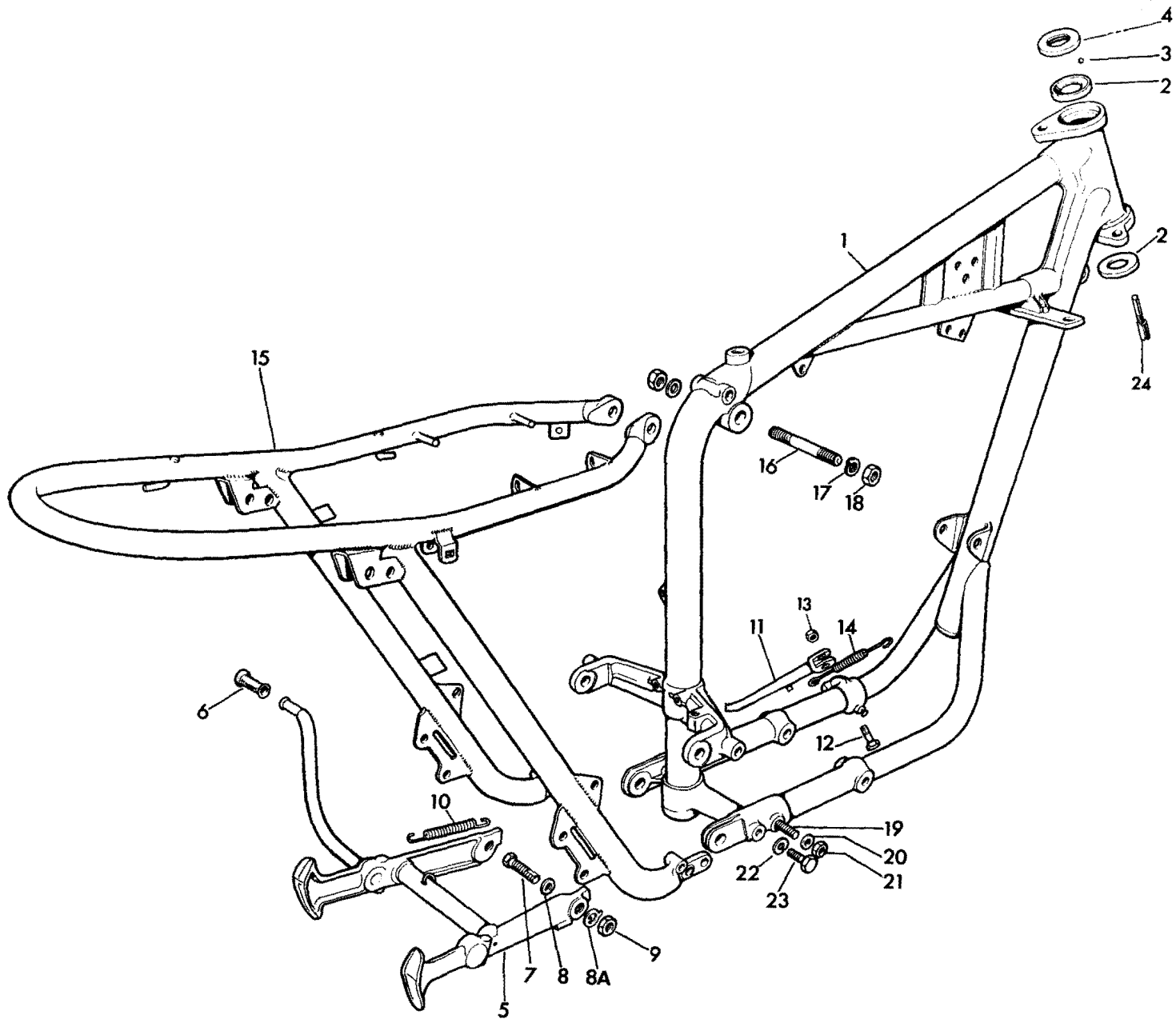

Fig. 12. FRAME

FRAME

1	F7843	Front frame	1	
2	H111	Steering race cup	2	
3	S70-3	Steel ball ($\frac{1}{2}$ in. diam.)	40	
4	H1018	Top cone and dust cover	1	
5	F5932	Centre stand	1	
6	T449	Pedal rubber	1	
7	F5678	Pivot bolt	2	
8	F5679	Plain washer	2	
8A	F4484	Tab washer	2	
9	F2725	Nut	2	
10	F4671	Return spring	1	
11	F7849	PROP STAND COMPLETE	1	
12	F7021	Pivot bolt	1	
13	15106/00/2	Self locking nut	1	
14	F8392	Return spring	1	
15	F8036	Rear frame	1	
16	F2842	Stud ($3\frac{7}{8}$ in. O.A.)	1	
17	S26-1	Spring washer	2	
18	S1-52	Nut	2	
19	F4369	Bolt ($2\frac{1}{4}$ in. U.H.)	2	
20	F4370	Plain washer	2	
21	DS47	Nut	2	
22	PCW73A	Spring washer	2	
23	S588	Bolt ($1\frac{3}{16}$ in. U.H.)	2	
24	F7155	Steering stop	2	

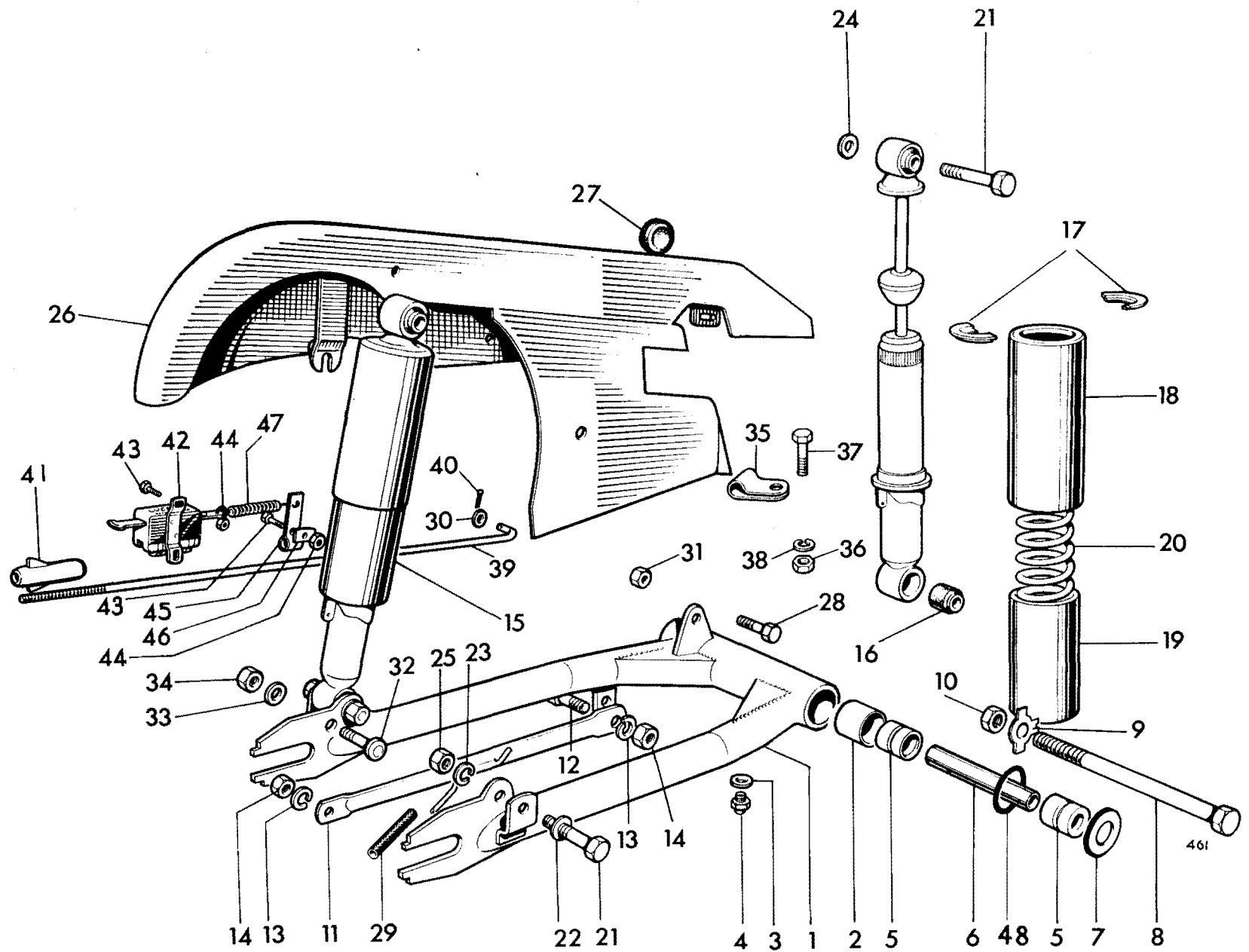

Fig. 13. SWINGING FORK AND SUSPENSION UNITS

SWINGING FORK AND SUSPENSION UNITS

1	F7845	SWINGING FORK	1	
2	82 F6042	Pivot bush	2	
3	NW100	Grease nipple	1	
4	WE170	Fibre washer	1	
5	F6821	Sleeve	2	
6	F5313	Distance tube	1	
7	82 F7848	Flanged washer	2	
8	21 S620 210620	Bolt (8 ⁵ / ₈ in. U.H.)	1	
9	82 F5944	Tab washer	1	
10	S545 210545	Nut	1	
11	F7365	Brake torque stay	1	
12	F5315	Bolt (3 ⁷ / ₈ in. U.H.)	1	
13	PCW73A	Spring washer	2	
14	DS47	Nut	2	
15	64054164	SUSPENSION UNIT	2	
-	64054465	Damper unit	2	(Not illustrated)
16	9054/316A	Bonded bush	4	
17	9054/171	Spring retainer	4	
18	9054/151	Outer dirt shield	2	
19	9054/47	Inner dirt shield	2	
20	9054/280	Spring, 100 lbs. Green/Green	2	
21	E2113	Unit fixing bolt (1 ⁵ / ₈ in. U.H.)	4	
22	S25-2	Plain washer	2	
23	S26-1	Spring washer	2	
24	GS308	Plain washer	3	
25	P0172A	Nut	4	
26	F7067	Chainguard	1	
27	F5536	Grommet	1	
28	H590	Bolt (1 ⁹ / ₈ in. U.H.)	1	
29	F7364	Rubber tube	1	
30	S25-13	Plain washer	1	
31	W1691	Self-locking nut	1	
32	F4136	Stepped bolt	1	
33	S25-3	Plain washer	1	
34	S1-51	Nut	1	
35	F3808	Clip	1	
36	F879	Nut	1	
37	F1369	Bolt (5/8 in. U.H.)	1	
38	S26-2	Spring washer	1	
39	F7386	Brake operating rod	1	
40	1/8 in. x 3/8 in.	Split pin	1	
41	F7387	Adjuster nut	1	
42	31437	Stop lamp switch, type 22B	1	
43	T1076	Screw (3/8 in. U.H.)	3	
44	F4717	Self locking nut	5	
45	F5412	Switch lever	1	
46	F5413	"D" washer	1	
47	F3158	Spring	1	
48	82 F8090	"O" ring	2	

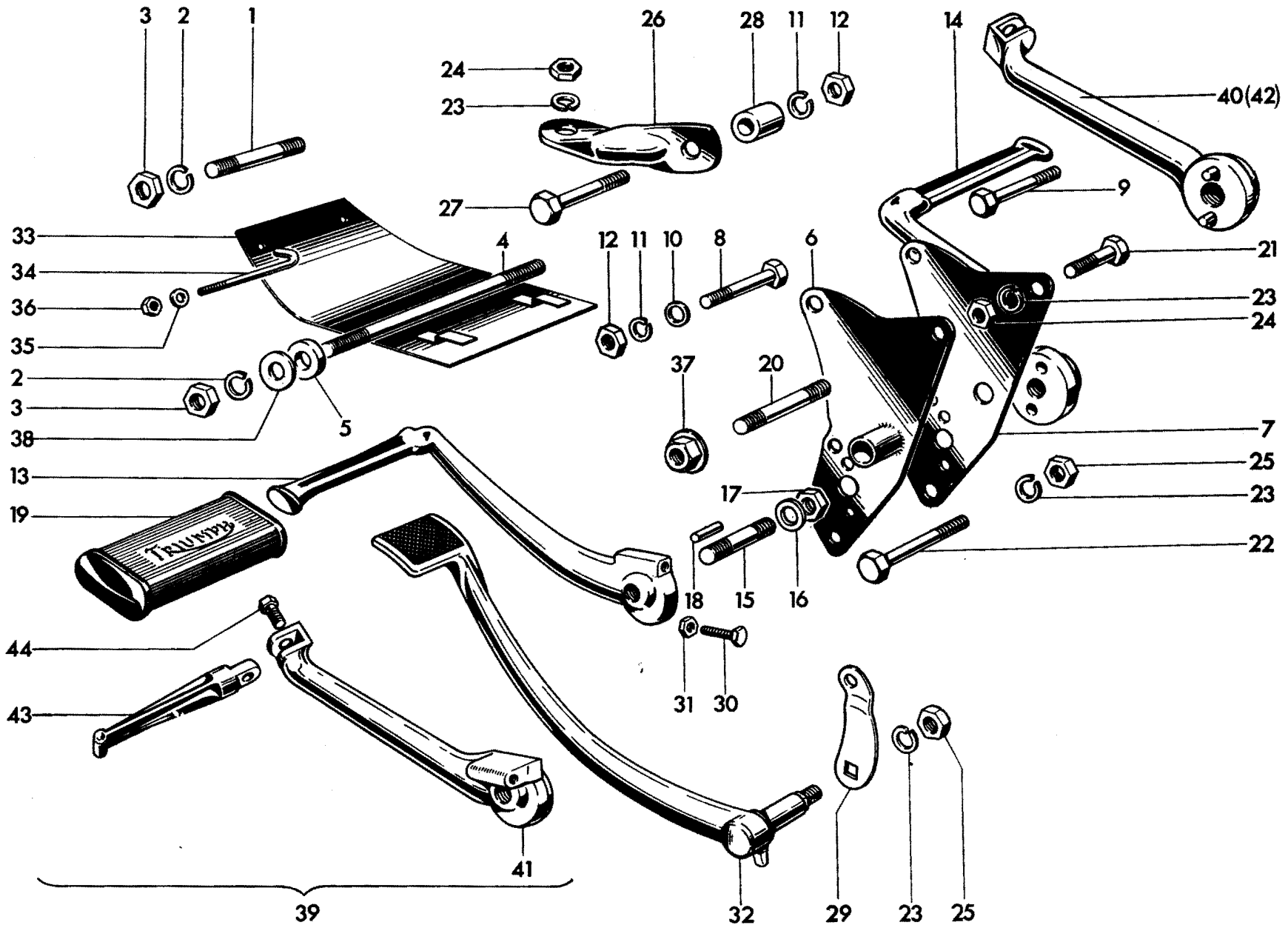

Fig. 14. ENGINE UNIT FITTING AND FOOTRESTS

ENGINE UNIT FITTINGS AND FOOTRESTS

1	F5469	Stud (3 $\frac{5}{16}$ in. O.A.)	1	
2	PCW73A	Spring washer	4	
3	DS47	Nut	4	
4	F6498	Stud (7 $\frac{7}{8}$ in. O.A.)	1	
5	F5532	Distance piece	2	
6	F6066	Left rear engine plate	1	
7	F5908	Right rear engine plate	1	
8	E4165	Bolt (1 $\frac{1}{4}$ in. U.H.)	2	
9	F5316	Bolt (1 $\frac{7}{8}$ in. U.H.)	2	
10	S25-3	Plain washer	4	
11	S26-3	Spring washer	6	
12	S1-51	Nut	6	
13	☞ F6069	Left footrest	1	TR6R & T120R
14	☞ F5910	Right footrest	1	
15	F5942	Stud (1 $\frac{9}{16}$ in. O.A.)	2	
16	S25-6	Plain washer	2	
17	S4-13	Nut	2	
18	F5943	Peg	4	
19	NF704	Footrest rubber	2	
20	S548	Stud (1 $\frac{3}{8}$ in. O.A.)	2	
21	F1031	Bolt (1 $\frac{5}{8}$ in. U.H.)	1	
21	H426	Bolt (2 $\frac{3}{4}$ in. U.H.)	1	
22	F3248	Bolt (1 $\frac{1}{2}$ in. U.H.)	2	
23	S26-1	Spring washer	9	
24	S1-52	Nut	7	
25	P0172A	Nut	3	
26	E4778	Engine torque stay	4	
27	F3805	Bolt (1 $\frac{5}{8}$ in. U.H.)	2	
28	F3069	Distance piece	4	
29	F6064	Brake pedal lever	1	
30	F1149	Bolt (1 $\frac{5}{8}$ in. U.H.)	1	
31	F879	Nut	1	
32	F6449	Brake pedal	1	
33	F5472	Crankcase undershield...	1	} TR6C
34	F5788	Hook bolt	2	
35	S25-1	Plain washer	2	
36	F879	Nut	2	
37	F7389	Nut	2	
38	F4370	Plain washer	2	
39	F6653	LEFT FOOTREST ASSEMBLY	1	} TR6C
40	F6654	RIGHT FOOTREST ASSEMBLY	1	
41	F6409	Left footrest	1	
42	F6410	Right footrest	1	
43	F6411	Footrest pedal	2	
44	F6655	Pivot bolt	2	

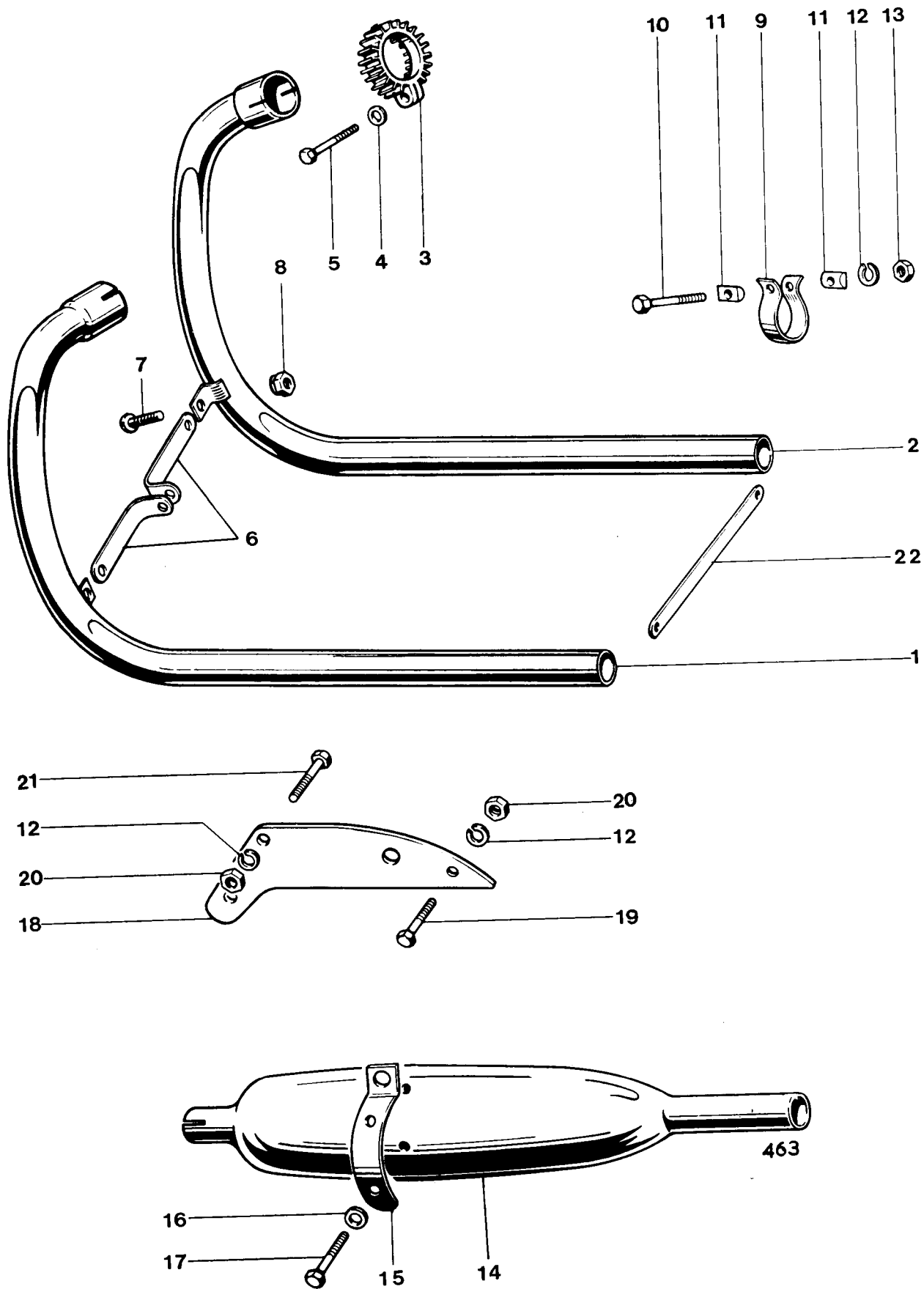

Fig. 15. EXHAUST PIPES AND MUFFLERS T120R, TR6R

EXHAUST PIPES AND MUFFLERS, T120R, TR6R (See also Page 43)

1	E5957	Left exhaust pipe	1	
2	E5958	Right exhaust pipe	1	
3	E4501	Finned clip	2	
4	E410A	Hemispherical washer	2	
5	E409	Bolt (1 $\frac{3}{8}$ in. U.H.)	2	
6	E6857	Stay	2	
7	E6179	Screw ($\frac{5}{8}$ in. U.H.)	2	
8	E7471	Self locking nut	2	
9	E2271	Clip	2	
10	F3430	Bolt (1 $\frac{3}{4}$ in. U.H.)	2	
11	E3768	"D" washer	4	
12	S26-3	Spring washer	8	
13	E1310	Nut	2	
14	E5866	Muffler	2	
15	E4951	Bracket	2	
16	S25-3	Plain washer	4	
17	F929	Bolt ($\frac{1}{2}$ in. U.H.)	4	
18	E4711	Pillion footrest support	2	
19	F2335	Bolt ($\frac{1}{4}$ in. U.H.)	2	
20	SI-51	Nut	6	
21	DS58	Bolt ($\frac{3}{4}$ in. U.H.)	2	
22	E5676	Stay	1	

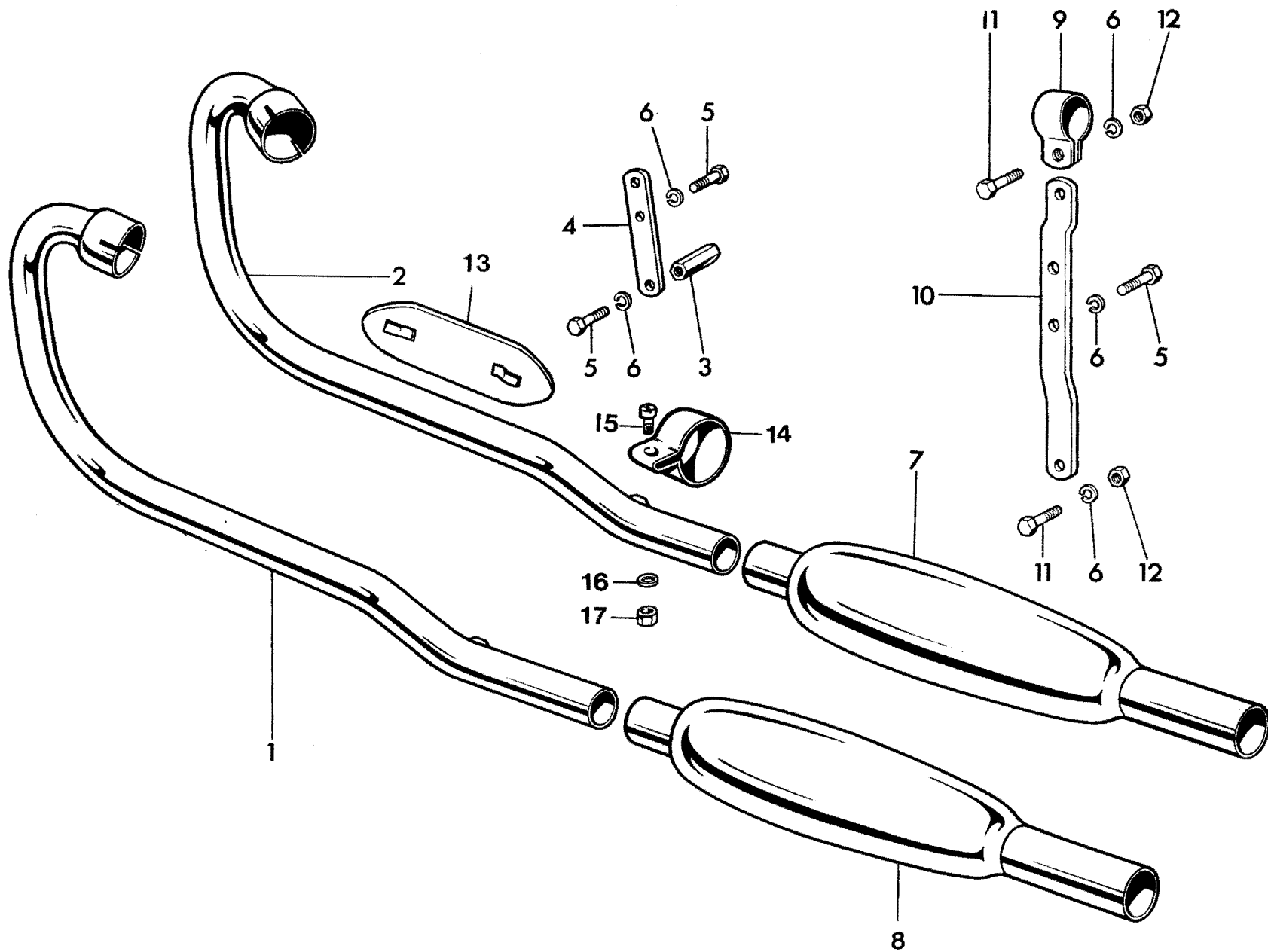

Fig. 16. EXHAUST PIPES AND MUFFLERS (TR6C)

EXHAUST PIPES AND MUFFLERS TR6C

1	E7024	Left exhaust pipe	1	
2	E7026	Right exhaust pipe	1	
3	E4889	Sleeve nut	2	
4	E6978	Stay	1	
5	H590	Bolt ($\frac{9}{16}$ in. U.H.)	4	
6	S26-3	Spring washer	6	
7	E6974	Upper muffler	1	
8	E6975	Lower muffler	1	
9	F7549	Clip	2	
10	E8724	Stay	1	
11	F2335	Bolt ($\frac{11}{16}$ in. U.H.)	2	
12	S1-51	Nut	2	
13	E4204	Leg guard	2	
14	E4207	Clip	4	
15	F4715	Screw	4	
16	E2351	Plain washer	4	
17	F3799	Self locking nut	4	

ASSEMBLY REF. No.1

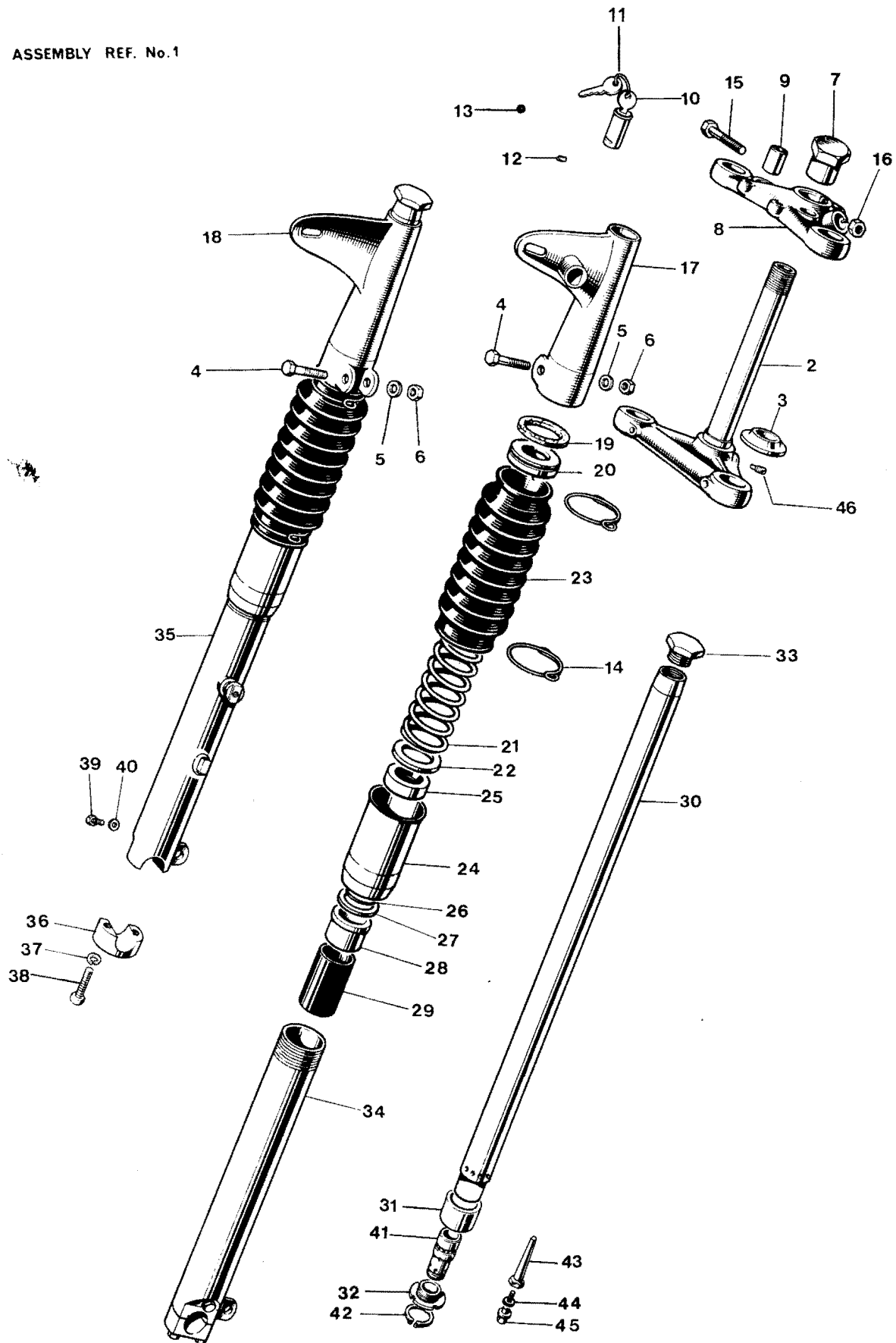

Fig. 17. TELESCOPIC FRONT FORK

Ref. No.	Part No.	DESCRIPTION	QUANTITY	REMARKS
TELESCOPIC FRONT FORK TR6R, T120R				
1	H2283	FORK ASSEMBLY	1	TR6R
1	H2285	FORK ASSEMBLY	1	T120R
2	H2278	Middle lug and stem	1	TR6R
2	H2280	Middle lug and stem	1	T120R
3	H439	Bottom cone	1	
4	H941	Pinch bolt (2¼ In. U.H.)	2	
5	S25-2	Plain washer	2	
6	E2412	Nut	2	
7	H2263	Fork stem sleeve nut (blind)	1	
8	H2100	Top lug	2	
9	H1527	Bonded bush	2	
10	F6738	Lock c/w 2 keys	1	
11	D623	Key (state serial number)	1	Key Nos. run from EJR1 to EJR50
12	S578	Grub screw	1	
13	H2266	Sealing washer	1	
14	H2083	Gaiter clip	4	
15	F1760	Pinch bolt (1½ In. U.H.)	1	
16	H379	Seated nut	1	
17	H2161	Left top cover	1	
18	H2162	Right top cover	1	
19	F4047	Cork washer	2	
20	H1657	Spring abutment	2	
21	H1891	Solo main spring (Yellow/Blue)	2	
21	H1892	Extra strong main spring (Yellow/Green)	2	Available
22	H1656	Plain washer	2	
23	H1645	Telescopic gaiter	2	
24	H1654	DUST EXCLUDER SLEEVE NUT	2	
25	H1500	Oil seal	2	
26	H2119	"O" ring	2	
27	H431	Plain washer	2	
28	H441	Top bearing	2	
29	H1896	Damping sleeve	2	
30	97 H2092 USE 3904	Stanchion	2*	
31	H443	Lower bearing	2	
32	H2091	Bearing nut	2*	
33	H2245	Cap nut	2*	
34	H1842	LEFT BOTTOM MEMBER c/w CAP	1	
35	H1843	RIGHT BOTTOM MEMBER c/w CAP	1	
36	H1844	Spindle cap	2	
37	S26-3	Spring washer	4	
38	H1070	Cap bolt (1⅞ In. U.H.)	4	
39	D519	Drain plug	2	
40	H430	Fibre washer	2	
41	H2154	Shuttle valve	2	
42	H2127	Circlip	2	
43	H2090	Restrictor	2	
44	H2126	Flanged bolt	2	
45	H1062	Aluminium washer	2	
46	H2107	Locating pin	1	

* Between engine numbers DU66246 and DU68363 the following parts are fitted and should only be replaced as a set: H1658 Cap nut, H3605 Stanchion, H2224 Bearing nut.

FORK ASSEMBLY REF. N°1

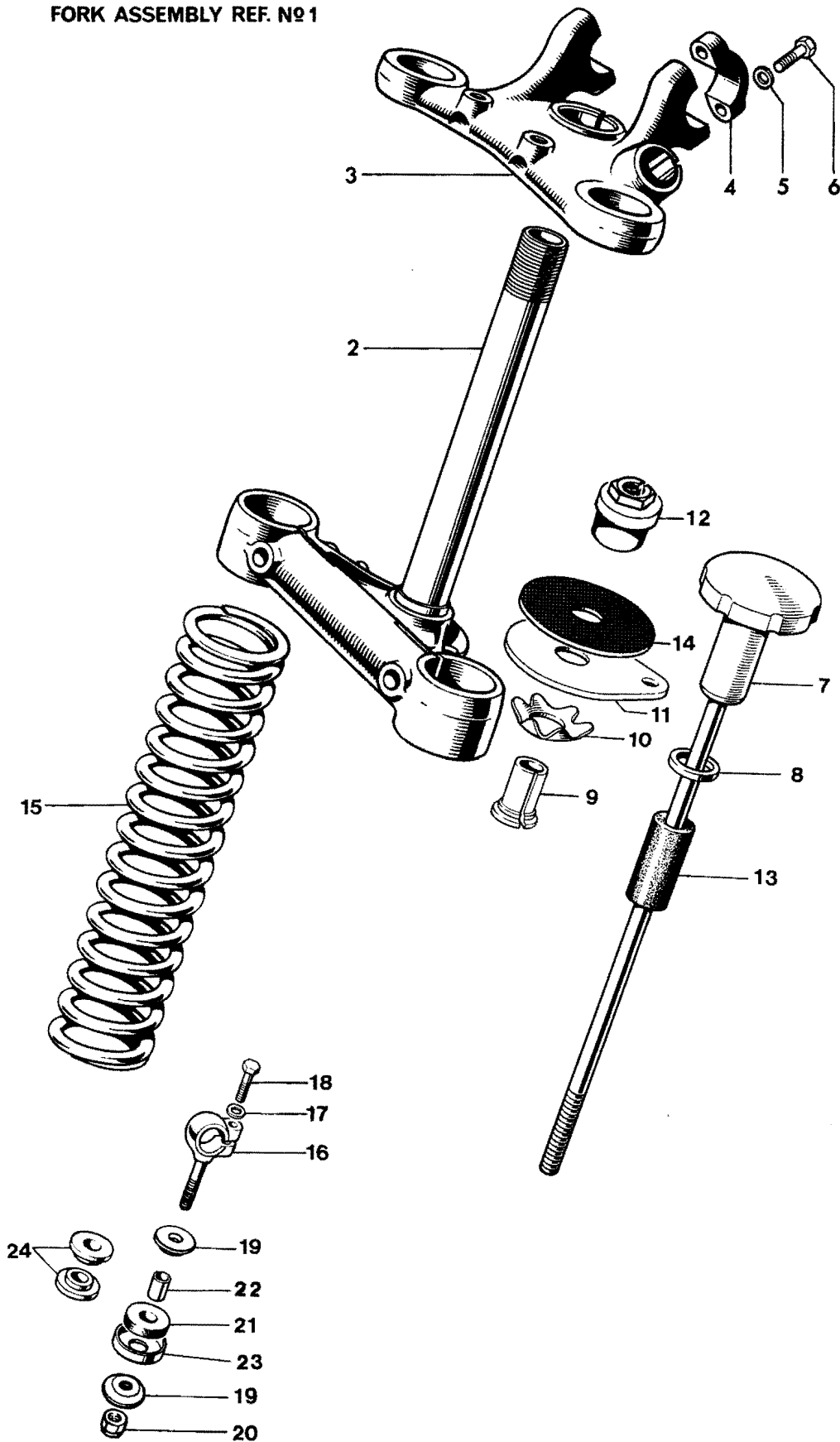

Fig. 18. TELESCOPIC FRONT FORK, TR6C

TELESCOPIC FRONT FORK AND STEERING DAMPER TR6C

1	H2284	FORK ASSEMBLY	1	
2	H2280	Middle lug and stem	1	
3	H2101	Top lug	1	
4	H722	Cap	2	
5	S25-3	Plain washer	4	
6	S589	Bolt (1 $\frac{1}{8}$ in. U.H.)	4	
7	H1142	Steering damper rod c/w knob	1	
8	H565	Plain washer	1	
9	H408	Adjuster sleeve	1	
10	H95	Spring plate	1	
11	H1797	Anchor plate	1	
12	H2108	Fork stem sleeve nut	1	
13	H1618	Rubber sleeve	1	
14	H435	Friction disc	1	
15	H1892	Main spring (yellow/green)	2	

All other parts are as listed on Page 45

HANDLEBAR MOUNTINGS

16	H1523	Handlebar eyebolt	2	} TR6R, T120R
17	F1335	Plain washer	2	
18	H1340	Bolt (1 $\frac{1}{8}$ in. U.H.)	2	
19	H1529	Hemispherical washer	4	
20	F3955	Self-locking nut	2	
21	H1580	Steady rubber	2	
22	H1581	Distance piece	2	
23	F3814	Cup	2	} as required
24	H1616	Solid bush (for handlebar-mounted windscreen)		

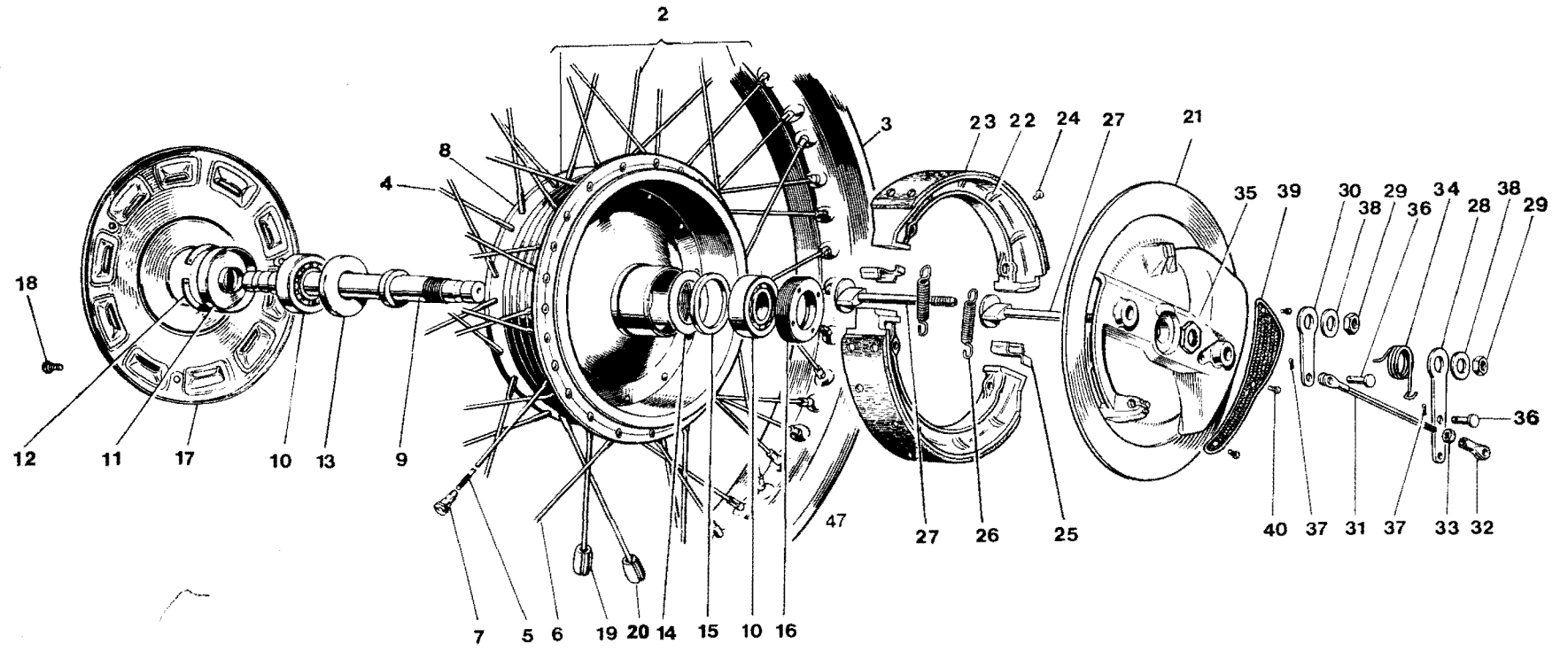

Fig. 19. FRONT WHEEL

FRONT WHEEL

1	W2050	FRONT WHEEL COMPLETE	1	
2	W1994	RIM, SPOKES AND HUB ASSEMBLY	1	
3	W1230	Front wheel rim (WM2-19)	1	
4	W1328	Spoke (8/10G x 5 $\frac{5}{8}$ in. straight) c/w nipple	20	
5	W1708	Spoke (8/10G x 4 $\frac{3}{4}$ in. 78°) c/w nipple	10	
6	W2023	Spoke (8/10G x 4 $\frac{7}{8}$ in. 100°) c/w nipple	10	
7	S79-2	Spoke nipple	40	
8	W1995	Hub and brake drum	1	
9	W1641	Wheel spindle	1	
10	W653	Bearing	2	
11	W1237	Dust cover	1	
12	T280	Circlip	1	
13	W1481	Grease retainer	1	
14	W1474	Grease retainer (brake side)	1	
15	W1238	Backing ring	1	
16	W582	Retaining ring	1	
17	W1992	Cover plate	1	
18	S064	Fixing screw	3	
19	W1197	Balance weight, $\frac{1}{4}$ oz.		as required
20	W1198	Balance weight, 1 oz.		as required
21	W1990	Brake anchor plate	1	
22	W1996	BRAKE SHOE c/w LINING	2	
23	W1998	Brake lining	2	
24	W2059	Brass rivet	16	
25	W2026	Abutment pad	2	
26	W135	Shoe return spring	2	
27	W2001	Brake cam	1	
28	W2000	Brake cam lever (front)	1	
29	14-0302/001	Nut	2	
30	W1999	Brake cam lever (rear)	1	
31	W2003	Rod	1	
32	W2005	Fork end, threaded	1	
33	14-0401/001	Locknut	1	
34	W592	Lever return spring	1	
35	W1246	Anchor plate nut	1	
36	WF32	Pivot pin	2	
37	—	Split pin	2	
38	S25-6	Plain washer	2	
39	W1991	Anchor plate gauze (for air scoop)	1	
40	S650	Taptite screw	3	

50

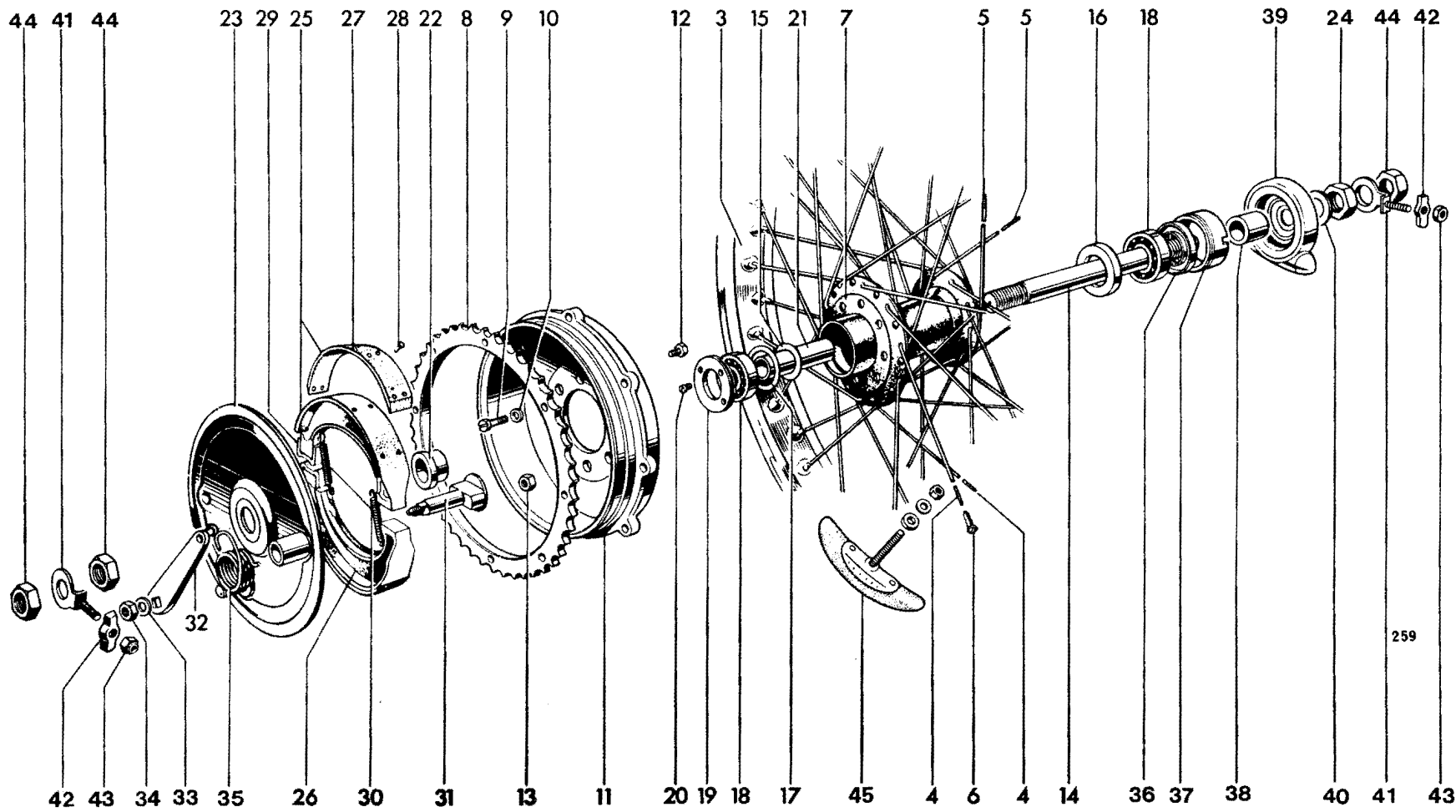

Fig. 20. REAR WHEEL

Ref. No.	Part No.	DESCRIPTION	QUANTITY	REMARKS
REAR WHEEL				
1	W1742	REAR WHEEL COMPLETE	1	
2	W1486	RIM, SPOKES AND HUB ASSEMBLY	1	
3	W1007	Rear wheel rim WM3-18	1	
4	W1107	Spoke (8/10G x 7 $\frac{9}{16}$ in. 90°) c/w nipple	20	
5	W1108	Spoke (8/10G x 7 $\frac{7}{8}$ in. 90°) c/w nipple	20	
6	S79-2	Spoke nipple	40	
7	W1472	Hub	1	
8	W1499	Sprocket, 46T	1	
9	W1500	Bolt ($\frac{1}{2}$ in. U.H.)	8	
10	E1612	Serrated washer	8	
11	W1498	Brake drum	1	
12	W1690	Bolt ($\frac{1}{2}$ in. U.H.)	8	
13	W1691	Self locking nut	8	
14	W1281	Wheel spindle	1	
15	W1474	Grease retainer (brake side)	1	
16	W1654	Grease retainer	1	
17	W1022	Backing ring	1	
18	W653	Bearing	2	
19	W1021	RETAINING RING	1	
20	W1710	Locking screw ($\frac{5}{16}$ in. U.H.)	1	
21	W1278	Distance tube	1	
22	W1024	Distance piece	1	
23	W1112	Brake anchor plate	1	
24	W1282	Nut	1	
25	W1406	LEADING BRAKE SHOE C/W LINING	1	
26	W1407	TRAILING BRAKE SHOE C/W LINING	1	
27	NW243	Brake lining	2	
28	W129	Brass rivet	16	
29	W1415	Thrust pad	2	
30	W135	Shoe return spring	2	
31	W1083	Brake cam	1	
32	W2015	Brake cam lever	1	
33	S25-6	Plain washer	1	
34	S1-52	Nut	1	
35	W1090	Lever return spring	1	
36	W1635	Grease retainer	1	
37	W1476	Speedometer adaptor	1	
38	W1477	Distance piece	1	
39	D637	Speedometer gearbox	1	
40	W1280	Plain washer	1	
41	W1134	Chain adjuster	2	
42	W1015	Adjuster end plate	2	
43	W1058	Self-locking nut	2	
44	F1747	Spindle nut	3	
45	WM3	Tire security bolt	2	

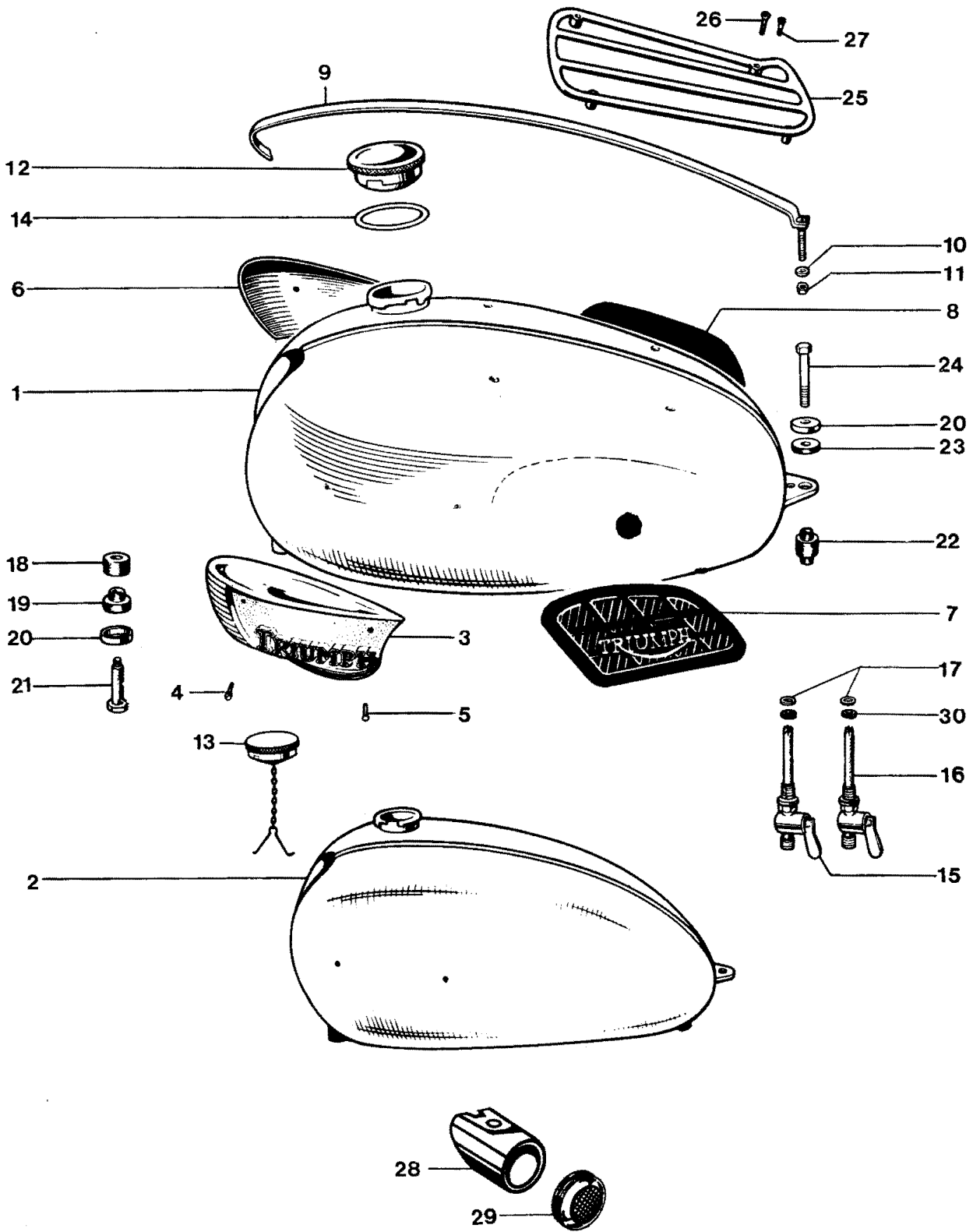

Fig. 22. GAS TANKS

Ref. No.	Part No.	DESCRIPTION	QUANTITY	REMARKS
GAS TANKS				
1	F7003	Petrol tank (4½ gallons)	1	TR6R
2	F6728	Petrol tank (2½ gallons)	1	TR6C, T120R
3	82 F6887	Styling unit (left)	1	
4	F4129	Styling unit screw (front)	2	
5	F7888	Styling unit screw (rear)	2	
6	82 F6888	Styling unit (right)	1	
7	F8192	Left knee grip	1	
8	F8193	Right knee grip	1	
9	F5398	Centre styling strip	1	TR6R
10	F4019	Serrated washer	1	
11	H919	Nut	1	
12	F3220	FILLER CAP	1	
13	F3219	FILLER CAP c/w JACK CHAIN	1	TR6C
14	F4048	Joint washer	1	
15	F4971	Petrol tap (left) ... 83.280.1	1	
16	F4972	Petrol tap with reserve tube ... 83.280.0	1	
17	F8198	Tap seal	2	
18	F5228	Rubber washer	2	
19	F5229	Spigot rubber	2	
20	F3814	Cup	3	
21	F1808	Shouldered bolt	2*	
22	F5336	Double spigot rubber	1	
23	F967	Rubber washer	1	
24	F7388	Bolt (1½ in. U.H.)	1	
25	F3917	Parcel grid	1	TR6R
26	F2936	Screw	1	
27	F4384	Rubber blanking plug	as required	
28	F8194	Reflector bracket	2	
29	57161	Reflector, AMBER	2	
—	D680	Decal—BONNEVILLE	1	
—	D1920	Decal—TROPHY 650	1	TR6C
—	D1918	Decal—TIGER 650	1	TR6R
30	F10002	Steel washer	2	
—	F10006	Nut for petrol tap	2 not illustrated	

* Later machines replace bolt F1808 with: F9298 Stud 2off 14-1302/001 Self-lock nut 2 off

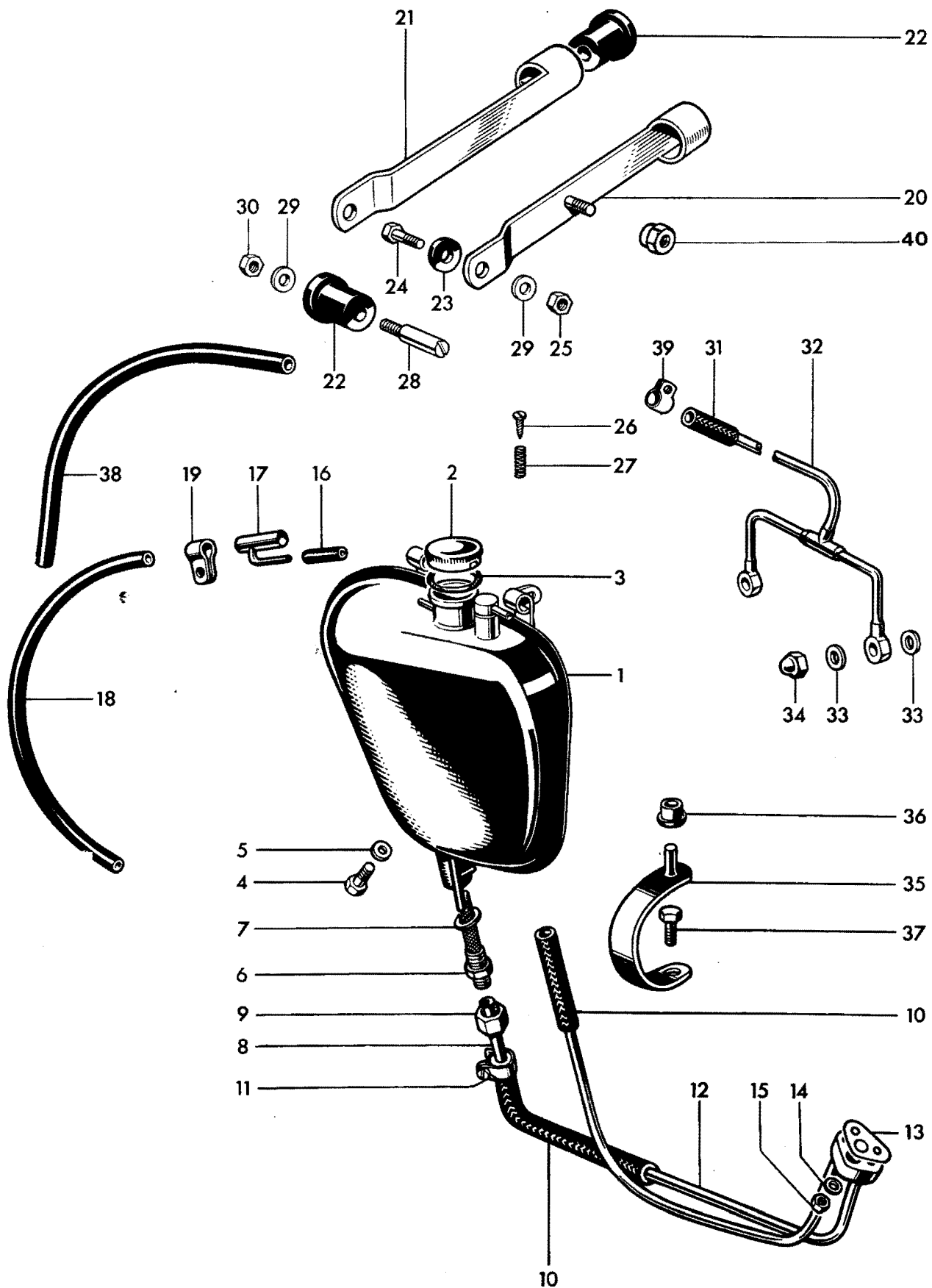

Fig. 23. OIL TANK

OIL TANK

1	F7836	Oil tank ...	1	
2	F3216	FILLER CAP ...	1	
3	F4047	Joint washer ...	1	
4	F5343	Drain plug ...	1	
5	PT104B	Fibre washer ...	1	
6	F3179	Oil tank filter ...	1	
7	F1713	Fibre washer ...	1	
8	F3655	Upper feed pipe ...	1	
9	F3182	Union nut ...	1	
10	E4594	Flexible connector ...	2	
11	E6848	Clip ...	4	
12	E6930	Oil pipes and junction block ...	1	
13	E3763	Joint washer ...	1	
14	E3446	Plain washer ...	1	
15	E1310	Nut ...	1	
16	E6356	Vent pipe ...	1	
17	E5370	"T" piece ...	1	
18	F7353	Extension pipe ...	1	
19	F3098	Clip ...	2	
20	F9255	Front strap ...	1	
21	F8028	Rear Strap ...	1	
22	F6673	Spigot rubber ...	4	
23	F6968	Rubber washer ...	2	
24	14-0103/001	Bolt ($\frac{3}{4}$ in. U.H.) ...	2	
25	15104/00/2	Self locking nut ...	2	
26	F6511	Metering screw ...	1	
27	F6874	Coil spring ...	1	
28	F6672	Screwed peg ...	2	
29	S25-13	Plain washer ...	4	
30	F879	Nut ...	2	
31	E6353	Rubber connector ...	1	
32	E6349	Rocker oil feed pipe ...	1	
33	E1335	Copper washer ...	4	
34	E1435	Domed nut ...	2	
35	F6147	Bracket ...	1	
36	F6039	Grommet ...	1	
37	14-0113/001	Bolt ($\frac{1}{2}$ in. U.H.) ...	1	
38	F7352	Flexible pipe ...	1	
39	E6849	Clip ...	1	
40	F8034	Sleeve nut ...	1	

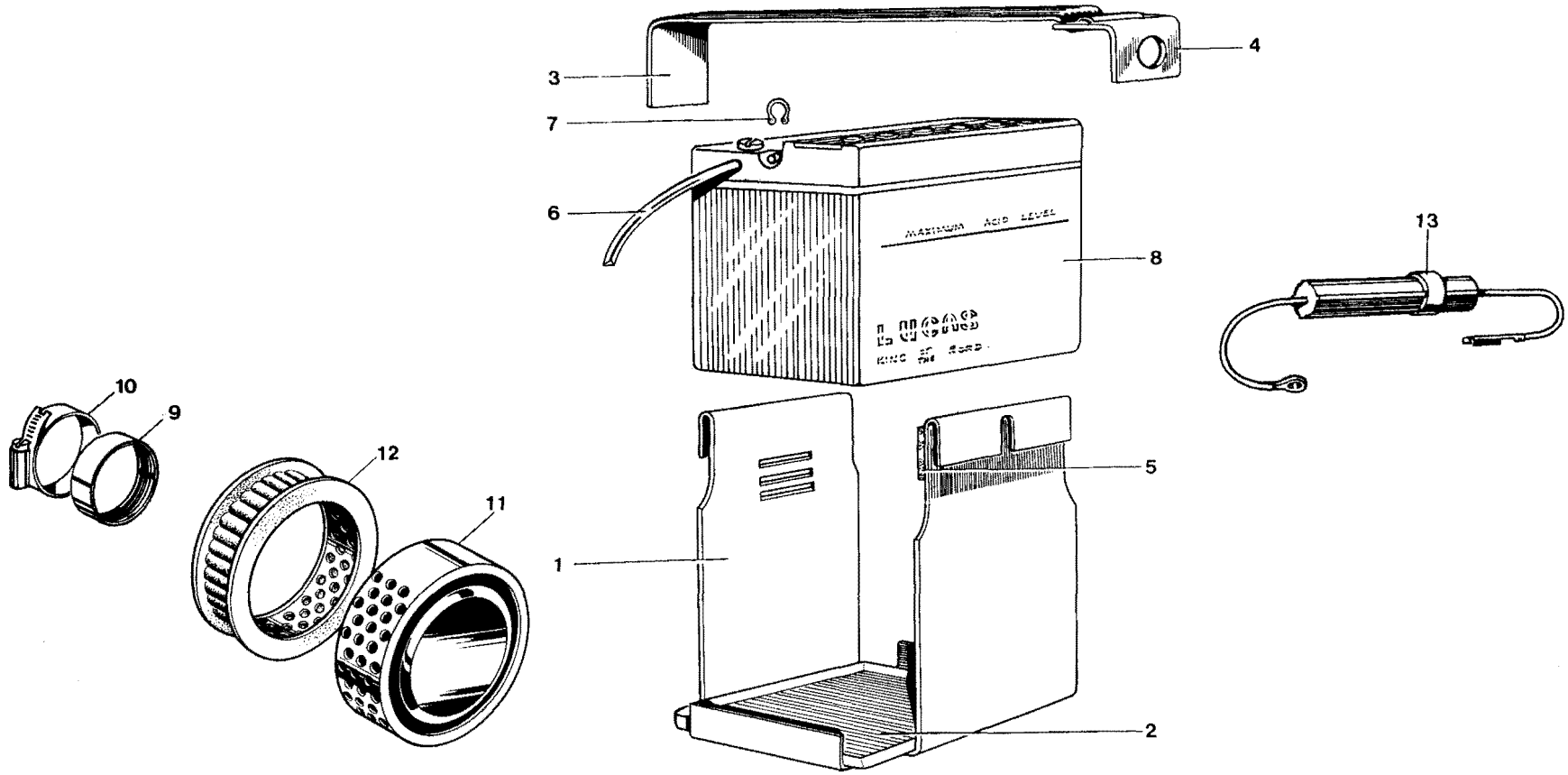

Fig. 24. BATTERY CARRIER AND AIR FILTERS

BATTERY CARRIER AND AIR FILTERS

1	F8024	Battery carrier	1	
2	F8091	Battery carrier rubber tray	1	
3	F8033	Battery carrier strap	1	
4	F8032	Battery strap anchorage	1	
5	F8031	Battery carrier rubber strip	1	
—	A52	Transfer positive earth	1	
6	F7431	Vent pipe	1	
7	F7892	Circlip, vent pipe	1	
8	PUZ5A	Battery	1	
9	F7632	Adaptor	1	} TR6R, TR6C
10	D177/9	Clip	1	
11	F6432	AIR FILTER	1	} T120R
12	F5694	Filter element (Paper)	1	
11	F8196	AIR FILTER	1	
12	F6866	Filter element (Cloth)	1	
13	54938986	Fuse assembly	1	

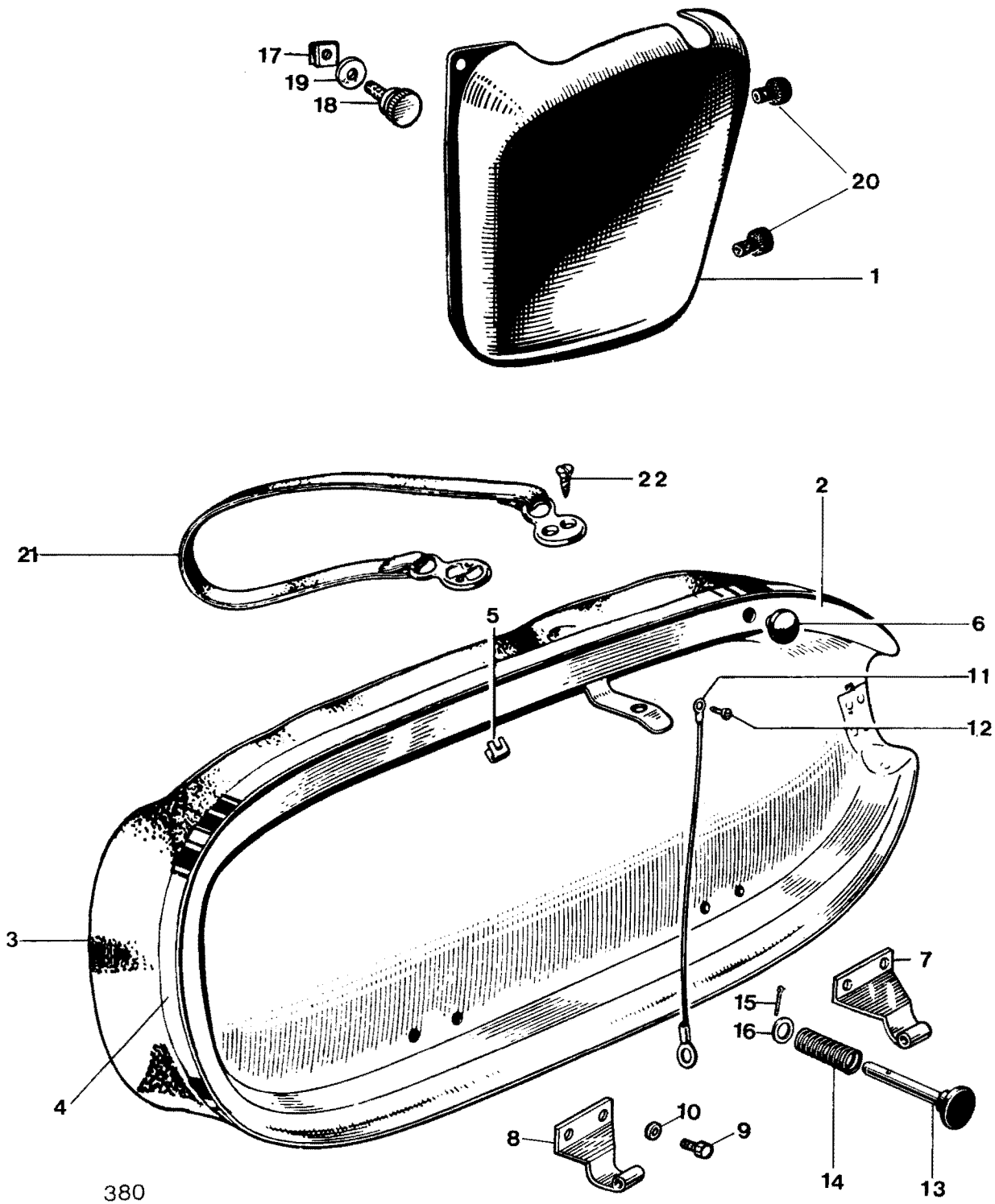
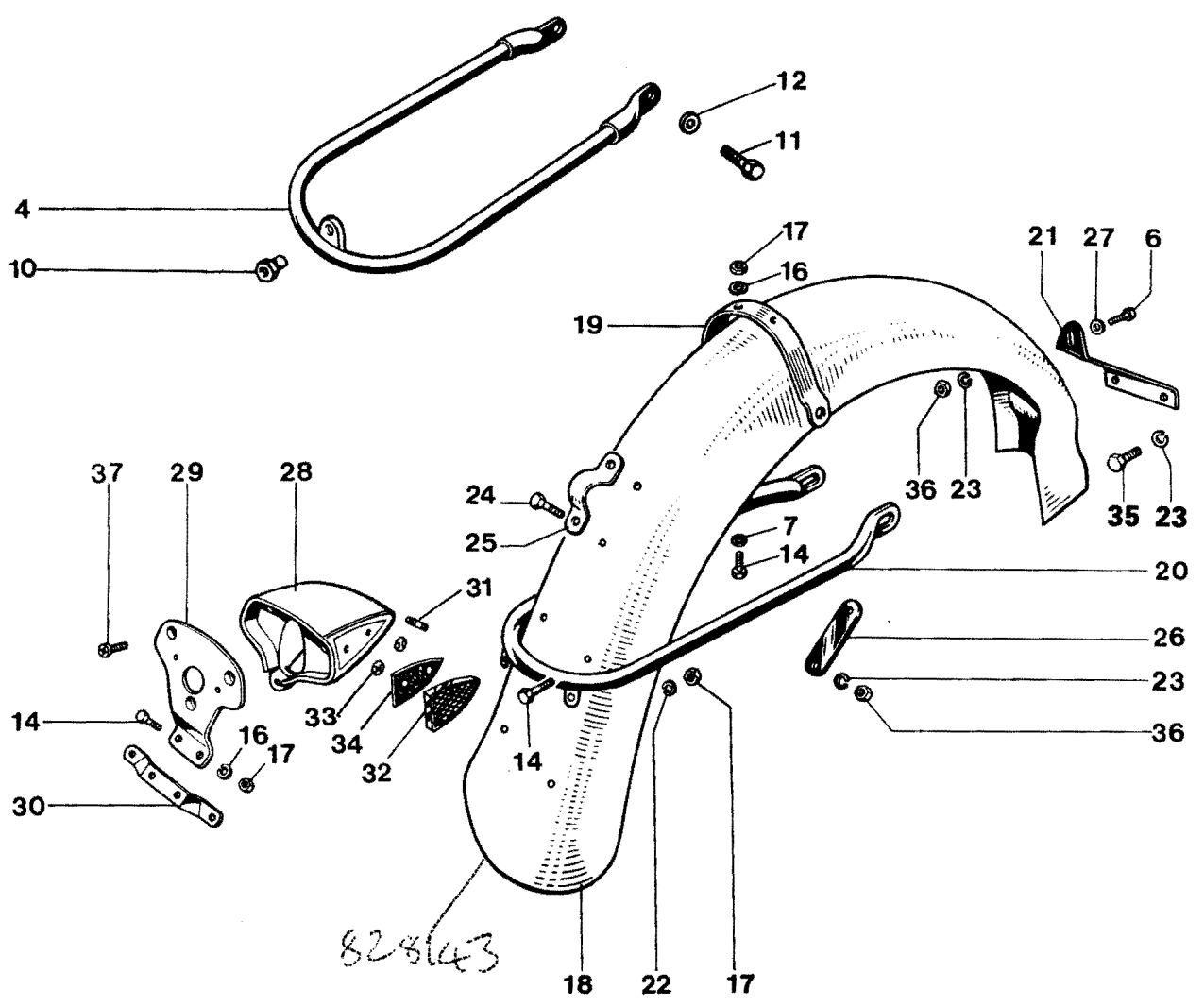
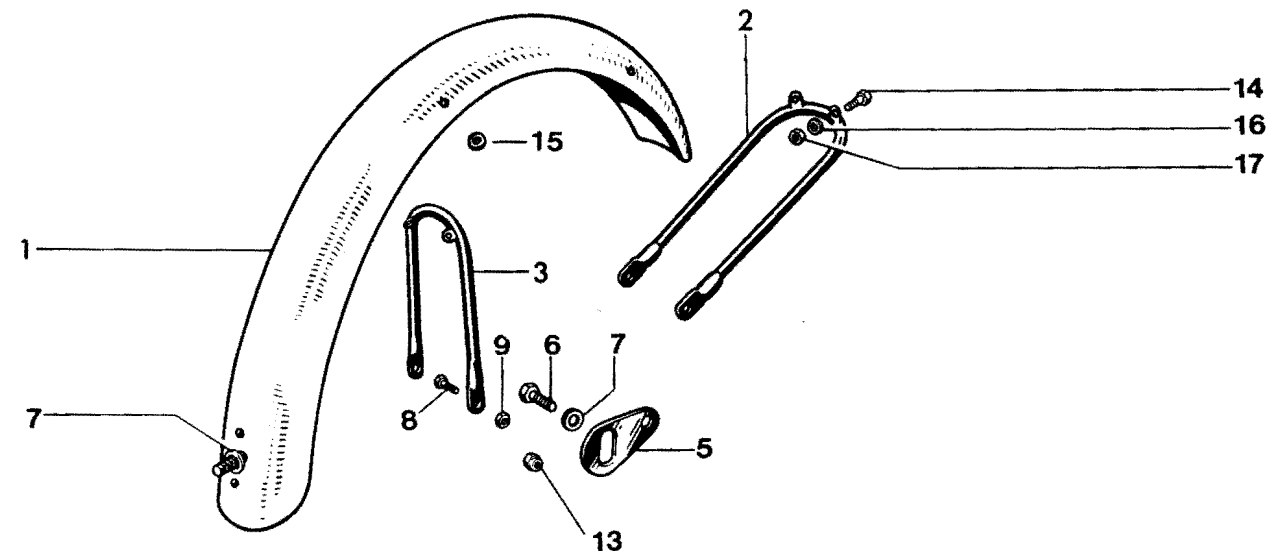

Fig. 25. PANEL AND TWINSEAT

PANEL AND TWINSEAT

1	F8042	Left panel and toolbox	1	
	60 D1918	Decal—TIGER 650	1	TR6R (Not illustrated)
	60 D1920	Decal—TROPHY 650	1	TR6C (Not illustrated)
	60 D680	Decal—BONNEVILLE	1	T120R (Not illustrated)
2	F8204	TWINSEAT (black top)	1	
3	F7489	Twinseat cover (black top)	1	
4	D696	Trim strip	1	
5	D697	Trim strip sprag	4	
6	F7835	Rubber buffer	1	
7	F8026	Hinge—front	1	
8	F7862	Hinge—rear	1	
9	14-0101/001	Bolt ($\frac{1}{2}$ in. U.H.)	4	
10	S26-2	Spring washer	4	
11	D374	Check wire	1	
12	F4483	Self tapping screw	1	
13	F7560	Seat catch plunger	1	
14	F4228	Spring	1	
15	E1719A	Plain washer	1	
16	$\frac{3}{32}$ in. x $\frac{1}{2}$ in.	Split pin...	1	
17	S653	Panel nut	1	
18	F8044	Panel knob	1	
19	F8132	Washer	1	
20	F6673	Panel grommet	2	
21	F7553	Safety strap	1	} Alternative
22	F4365	Self tapping screw	4	



828643

Fig. 26. FENDERS

Ref. No. Part No. DESCRIPTION QUANTITY REMARKS

FENDERS

Ref. No.	Part No.	DESCRIPTION	QUANTITY	REMARKS
1	H2276	Front fender (stainless steel)	1	T120R, TR6C
1	H2268	Front fender (painted)	1	TR6R
2	H1681	Front stay	1	
3	H1683	Centre bridge	1	
4	H1678	Bottom stay <i>USE... 97.1492</i>	1	
5	H1685	Bracket	2	
6	F929	Bolt ($\frac{1}{2}$ in. U.H.)	5	
7	F4299	Plain washer	5	
8	DS55	Bolt ($\frac{5}{16}$ in. U.H.)	2	
9	T224	Nut	2	
10	NS362	Spigot nut	1	
11	DS55	Bolt ($\frac{11}{16}$ in. U.H.)	2	
12	GS203	Plain washer	2	
13	W1691	Nut, self locking	2	
14	DS57	Bolt ($\frac{7}{16}$ in. U.H.)	10	
15	WE170	Fibre washer	4	
16	S25-1	Plain washer	13	
17	F879	Nut	13	
18	F8143	Rear fender	1	TR6R
18	F8144	Rear fender (stainless steel)	1	T120R, TR6C
19	F6915	Fender bridge	1	
20	F7860	Lifting handle	1	
21	F6851	Bracket	1	
22	S26-2	Spring washer	2	
23	S26-3	Spring washer	5	
24	H590	Bolt ($\frac{9}{16}$ in. U.H.)	2	
25	82 F5994	Clip	1	
26	82 F6031	Backing plate	1	
27	F6310	Plain washer	1	
28	F8139	Tail lamp adaptor	1	
29	F6849	Tail lamp plate	1	
30	F6850	Number plate bracket	1	
31	E2980	Stud ($\frac{1}{2}$ in. O.A.)	1	
32	57111	Reflector	2	
33	F8195	Push fix	4	
34	F8140	Rubber mat	2	
35	14-0113/001	Bolt bracket to pivot lug	2	
36	S1-51	Nut	2	
37	F4715	Screw	3	

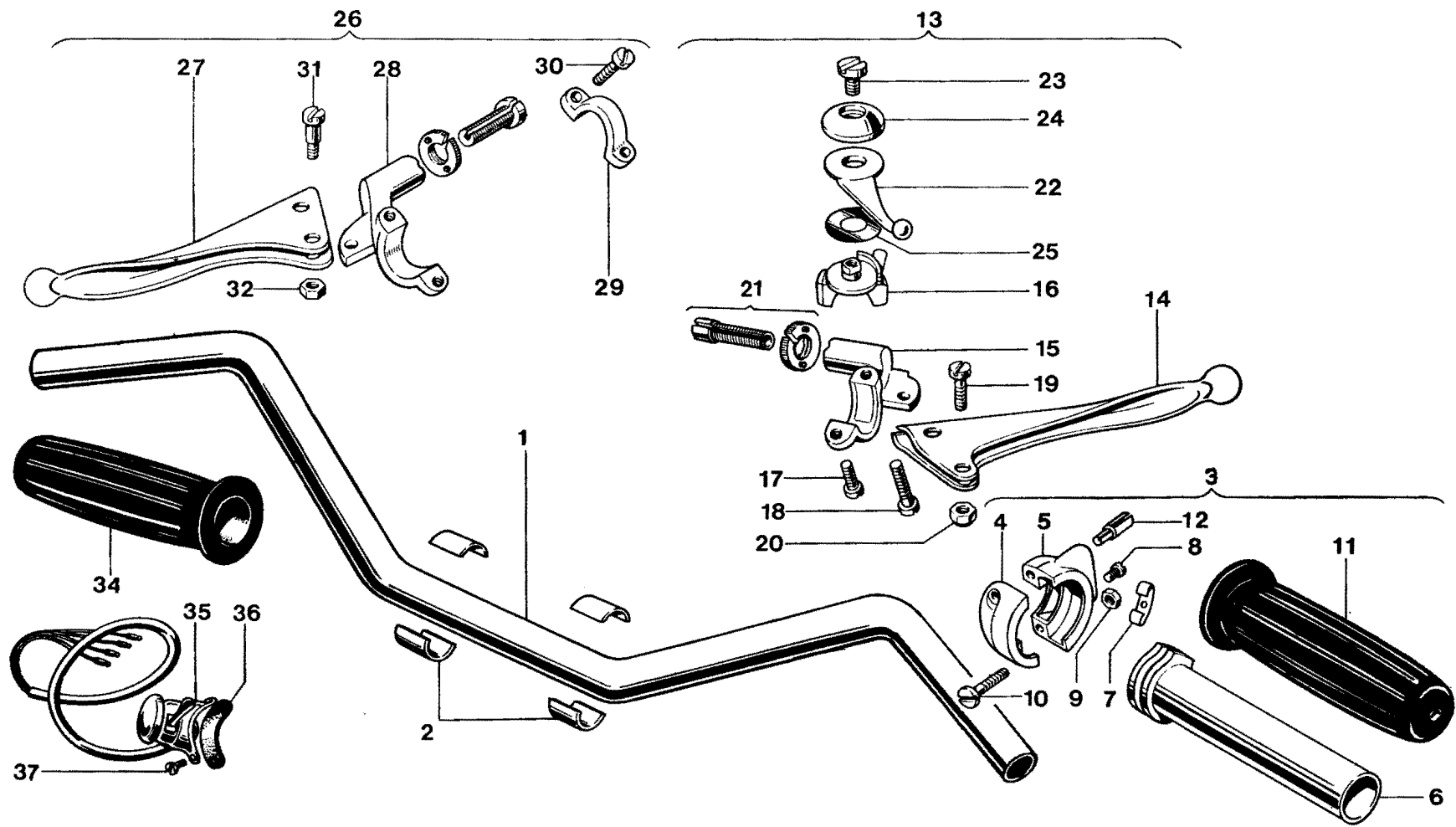

Fig. 27. HANDLEBARS AND CONTROL LEVERS

HANDLEBARS AND CONTROL LEVERS (SEE ALSO PAGE 65)

1	H1870	Handlebar	1	TR6R, T120R
1	H1511	Handlebar	1	TR6C
2	H1425	Packing piece	4	TR6R, T120R
3	16/364	TWISTGRIP	1	TR6C, TR6R
4	16/328	Body top half	1	
5	16/329	Body bottom half	1	
6	16/091	Rotor	1	
7	16/008	Friction spring	1	
8	16/009	Friction spring screw	1	
9	16/010	Locknut	1	
10	11/013	Screw	2	
11	H2125	Grip	1	
12	16/011	Cable stop	1	
13	18/978	FRONT BRAKE AND AIR LEVER ASSEMBLY	1	
14	18/754	Brake lever (ball end)	1	
15	18/777	Lever bracket	1	
16	12/594	Control body	1	
17	11/014	Screw	1	
18	11/013	Screw	1	
19	18/087	Fulcrum screw	1	
20	18/053	Self locking nut	1	
21	18/838/839	Cable adjuster and nut	1	
22	12/556	Lever	1	
23	12/607	Bolt	1	
24	12/606	Cap	1	
25	12/033	Spring washer	1	
26	18/952	CLUTCH LEVER ASSEMBLY	1	
27	18/752	Clutch lever (ball end)	1	
28	18/773	Clutch lever bracket	1	
29	12/595	Clamp	1	
30	11/014	Screw	2	
31	18/087	Fulcrum screw	1	
32	18/053	Self locking nut	1	
33	18/838/839	Cable adjuster and nut	1	
34	H2142	Handlebar grip	1	
35	31563	Horn push and dip switch	1	
36	380459	Backing rubber	1	
37	H1994	Self-tapping screw (½ in. U.H.)	2	

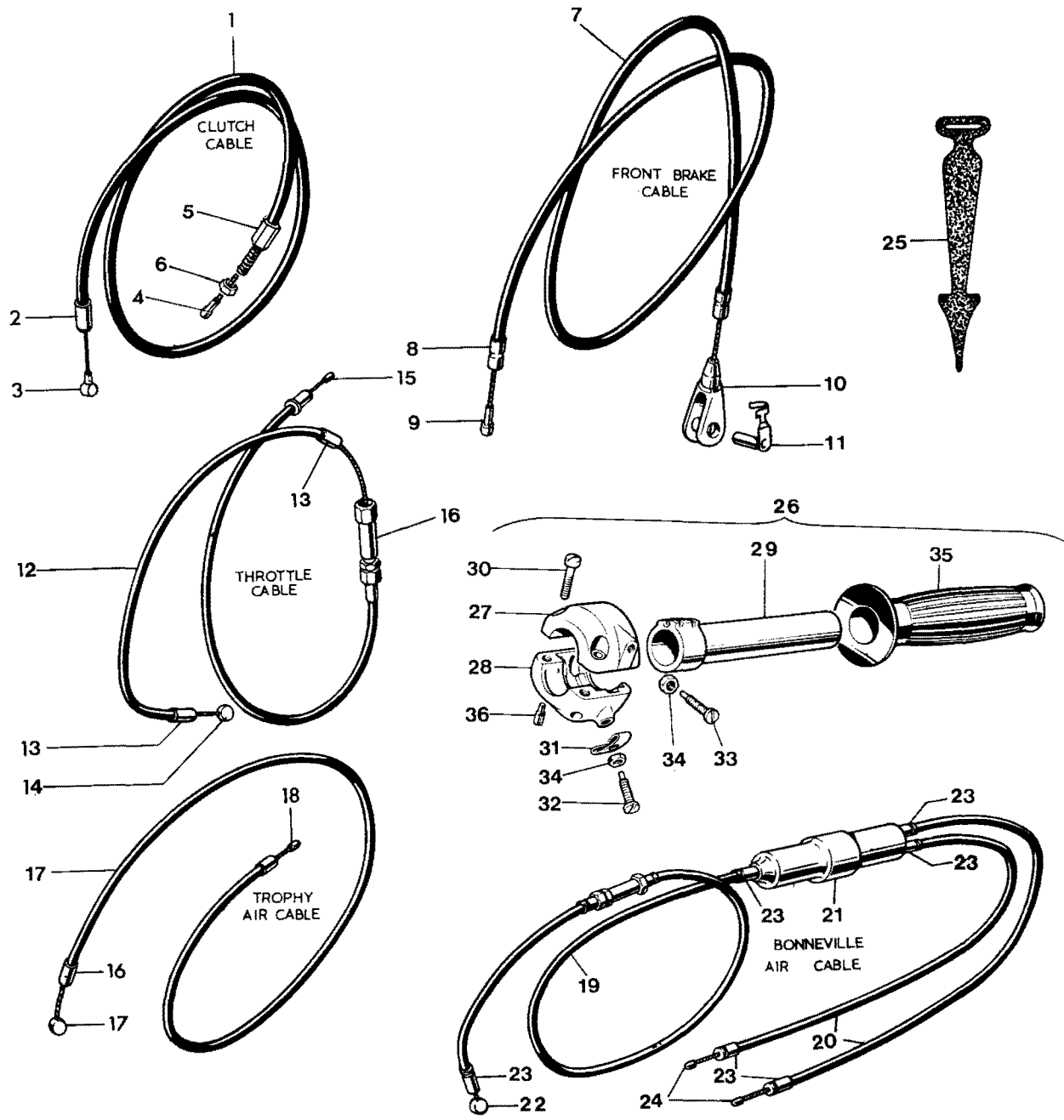

Fig. 28. CONTROL CABLES

Ref. No.	Part No.	DESCRIPTION	QUANTITY	REMARKS
----------	----------	-------------	----------	---------

CONTROL CABLES AND T120R TWISTGRIP

1	D667	CLUTCH CABLE	1	
2	D103	Ferrule	2	
3	D506	Nipple (Handlebar end)	1	
4	DS73	Nipple	1	
5	D668	Adjuster	1	
6	S672	Nut	1	
7	D665	FRONT BRAKE CABLE	1	
8	D103	Ferrule	2	
9	D506	Nipple (Handlebar end)	1	
10	D638	Fork end	1	
11	W2006	Pivot pin (spring-fix)	1	
12	D746	THROTTLE CABLE	1	TR6R, TR6C
12	D660	THROTTLE CABLE	1	T120R
13	D101	Ferrule	2	
14	D83	Nipple	1	
15	NS191	Nipple	1	
16	D104	Adjuster	1	
17	D747	AIR CONTROL CABLE	1	TR6, TR6C
18	D682	AIR CABLE ASSEMBLY	1	T120
19	D683	Lever cable	1	
20	D684	Carburettor cable	2	
21	D685	Junction box	1	
22	D83	Nipple (Handlebar end)	1	
23	D101	Ferrule	6	
24	NS191	Nipple	3	
25	D343/7	Clip, rubber		as required
26	313/13	TWIN ROTOR TWISTGRIP	1	T120R
27	313/008	Body top half	1	
28	313/009	Body bottom half	1	
29	313/013	Rotor	1	
30	4/048	Bolt	2	
31	16/008	Friction spring	1	
32	210/007	Adjuster screw	1	
33	210/008	Rotor stop	1	
34	210/009	Nut	2	
35	H2125	Grip	1	
36	16/011	Cable stop	2	

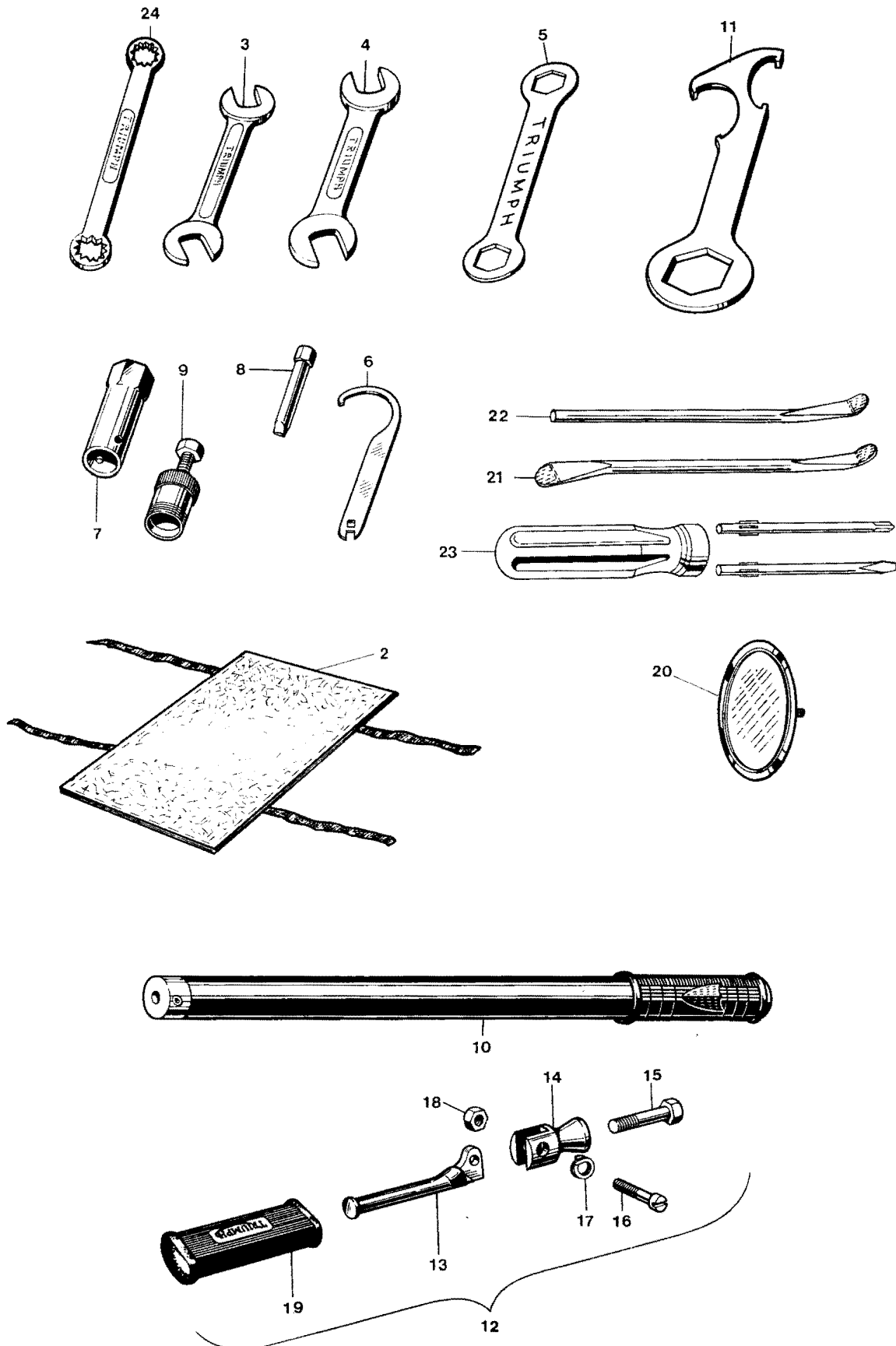

Fig. 29. TOOLKIT, PILLION FOOTRESTS AND LICENCE HOLDER

TOOLKIT, PILLION FOOTRESTS AND LICENCE HOLDER

Ref. No.	Part No.	DESCRIPTION	QUANTITY	REMARKS
1	D698	TOOLKIT COMPLETE	1	
2	D291	Tool roll	1	
3	NA55	Open spanner, $\frac{1}{4} \times \frac{5}{16}$ in. Whit.	1	
4	DA16	Open spanner, $\frac{3}{8} \times \frac{7}{16}$ in. Whit.	1	
5	DA311	Ring spanner, $\frac{5}{8} \times \frac{1}{2}$ in. Whit.	1	
6	D362	"C" spanner and tappet key	1	
7	D87	Plug spanner	1	
8	D496	Screwdriver for chain tensioner	1	
9	D662/3	Clutch hub extractor	as required	
10	D296	Tyre inflator	as required	
11	D220	Fork spanner (for cap nut)	as required	
12	F5552	PILLION FOOTREST	2	
13	F1694	Pedal	2	
14	F2268	Hanger	2	
15	F5535	Bolt ($\frac{1}{8}$ in. U.H.)	2	
16	F2271	Pivot bolt	2	
17	F2277	Thackeray (spring) washer	2	
18	S1-51	Nut	2	
19	F1695	Pedal rubber	2	
20	D261	Licence holder	as required	
21	NA14A	Tyre lever	1	
22	D801	Tyre lever and tommy bar	1	
23	D767	Screwdriver	1	
24	D370	Ring spanner, $\frac{3}{16} \times \frac{1}{4}$ ins. Whit.	1	

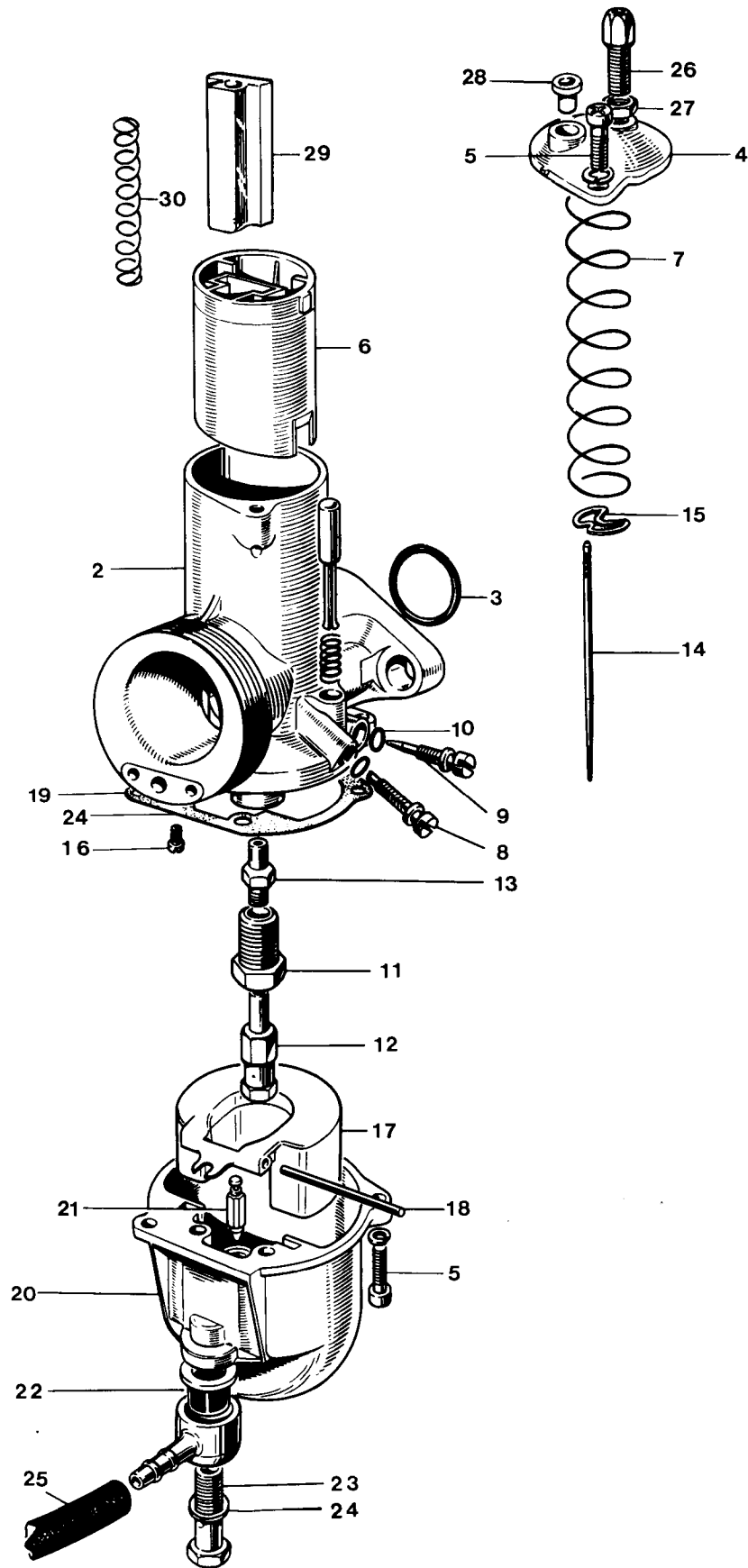

Fig. 30. AMAL CARBURETTER, TR6R TR6C

Ref. No.	Part No.	DESCRIPTION	QUANTITY	REMARKS
----------	----------	-------------	----------	---------

AMAL CARBURETTER TR6R, TR6C

1	930/23	CARBURETTER	1	
2	As above	Mixing chamber	1	
3	244/1048	"O" ring seal	1	
4	928/064	Mixing chamber top	1	
4	928/097	Mixing chamber top (for adjuster and ferrule)	1	Available
5	622/086	Screw	4	
6	928/060	Throttle valve (4 cutaway)	1	
7	622/061	Throttle return spring	1	
8	622/077	Throttle stop screw	1	
9	622/076	Air adjusting screw	1	
10	622/082	"O" ring	2	
11	622/080	Jet holder	1	
12	376/100	Main jet (230)	1	
13	622/079	Needle jet (0.107)	1	
14	922/063	Needle	1	
15	622/067	Needle clip	1	
16	124/026	Pilot jet (25)	1	
17	622/069	Float	1	
18	622/071	Float spindle	1	
19	622/073	Joint washer	1	
20	622/050	Float chamber	1	
21	622/068	Needle	1	
22	376/093	Filter	1	
23	622/078	Banjo bolt	1	
24	376/092	Fibre washer	1	
25	F9271	Petrol pipe	1	
26	4/035	Adjuster		Available
27	5/077	Locknut, adjuster		Available
28	6/132A	Cable ferrule	2	
29	928/062	Air slide	1	
30	622/065	Spring	1	

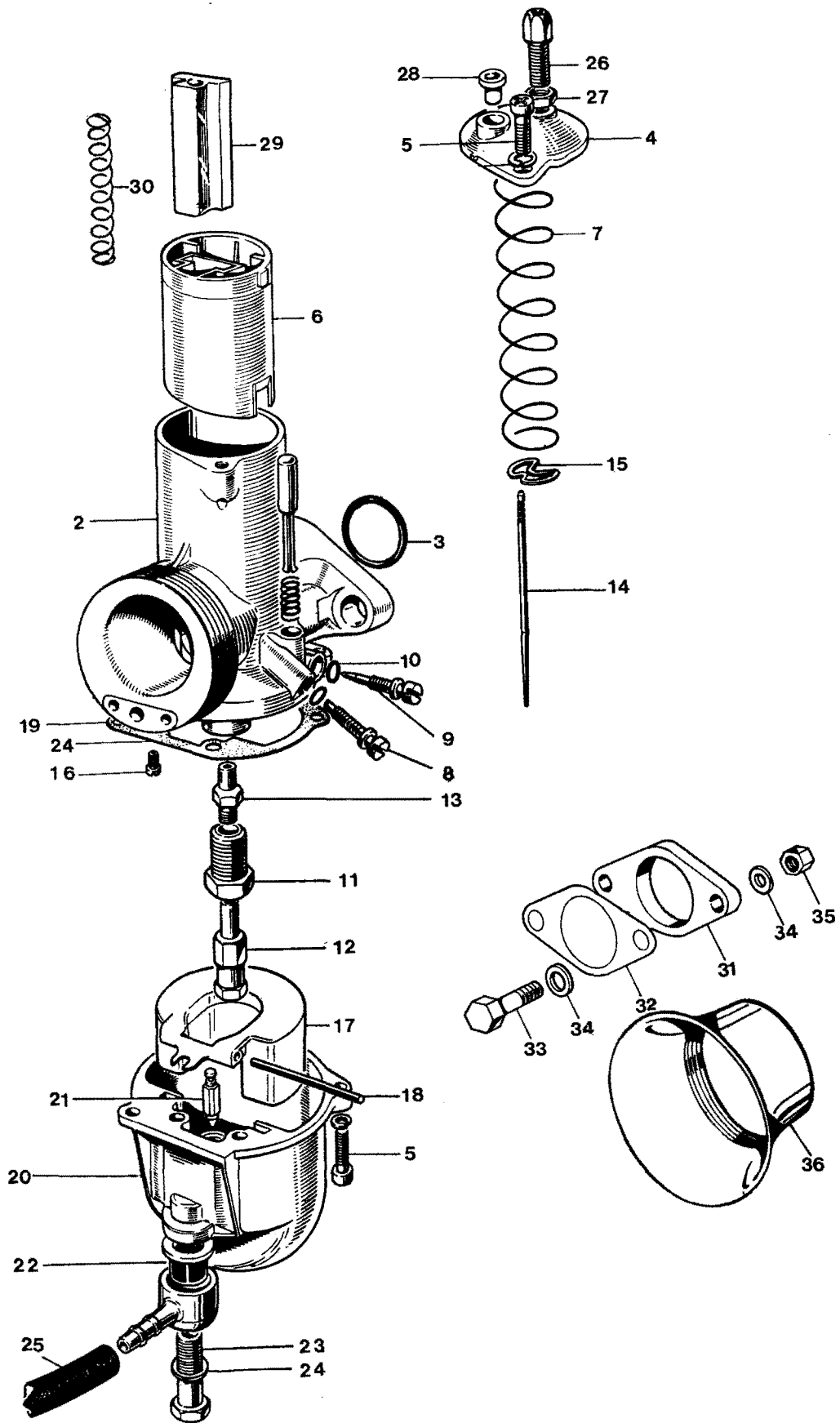

Fig. 31. AMAL CARBURETTER, T120R

Ref. No.	Part No.	DESCRIPTION	QUANTITY	REMARKS
----------	----------	-------------	----------	---------

AMAL CARBURETTER T120R

1	R930/10	CARBURETTER—L.H.	1	
1	R930/9	CARBURETTER—R.H.	1	
2	As above	Mixing chamber	2	
3	244/1048	"O" ring seal	2	
4	928/097	Mixing chamber top	2	
5	622/086	Screw	8	
6	928/060	Throttle valve (3 cutaway)	2	
7	622/061	Throttle return spring	2	
8	622/077	Throttle stop screw	2	
9	622/076	Air adjusting screw	2	
10	622/082	"O" ring	4	
11	622/080	Jet holder	2	
12	376/100	Main jet (220)	2	
13	622/079	Needle jet (0.107)	2	
14	922/063	Needle	2	
15	622/067	Needle clip	2	
16	124/026	Pilot jet (20)	2	
17	622/069	Float	2	
18	622/071	Float spindle	2	
19	622/073	Joint washer	2	
20	622/050	Float chamber	2	
21	622/068	Needle	2	
22	376/093	Filter	2	
23	622/078	Banjo bolt	2	
24	376/092	Fibre washer	2	
25	F8133	Petrol pipe	2	
26	4/035	Adjuster	2	
27	5/077	Locknut	2	
28	6/132A	Cable ferrule	2	
29	928/062	Air slide	2	
30	622/065	Spring	2	
31	E2968	Insulating block	2	
32	NA43A	Joint washer	2	
33	F2603	Bolt ($\frac{1}{8}$ in. U.H.)	4	
34	S25-3	Plain washer	8	
35	T224	Nut	4	
36	928/066	Air intake tube	as required	

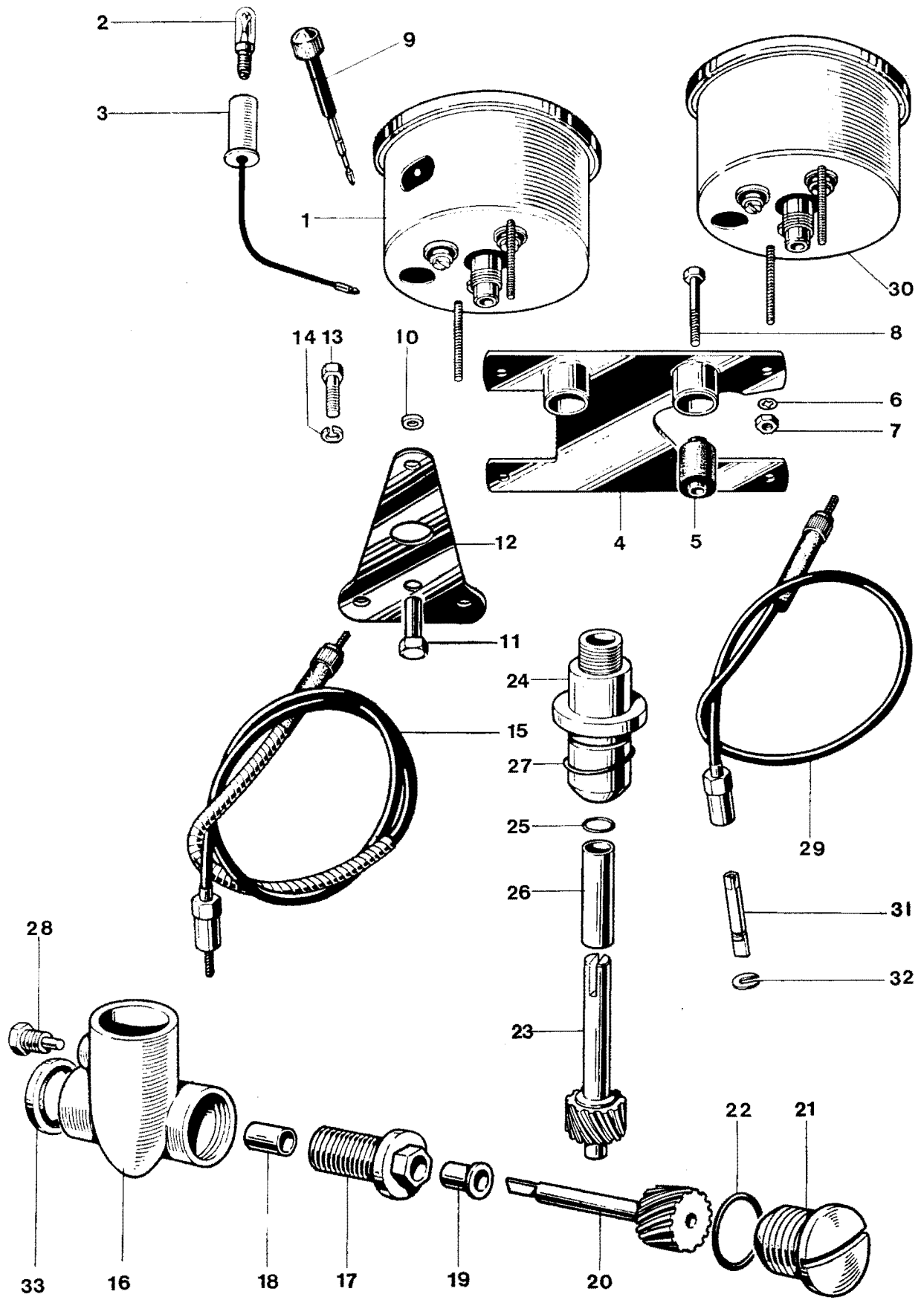

Fig. 33. SPEEDOMETER AND TACHOMETER

Ref. No.	Part No.	DESCRIPTION	QUANTITY	REMARKS
SPEEDOMETER AND TACHOMETER				
1	SSM5001/06	Speedometer head MPH	1	
—	31-315-135	Brass fitting at cable connection	1	Not illustrated
2	554734	Bulb holder	1	
3	987	Bulb, 3.W. M.E.S.	1	
4	H1946	MOUNTING BRACKET	1	} TR6R, T120R
5	H1929	Metalastik bush	2	
6	30-282-014-11	Washer	2	
7	30-276-037-11	Nut	2	
8	S590	Bolt (1- $\frac{3}{8}$ in. U.H.)	2	
9	41-148-203-10	Trip control	1	
10	H1702	Distance piece	2	} TR6C
11	H1701	Sleeve nut	2	
12	H2138	Bracket	1	
13	14-0101/001	Bolt ($\frac{1}{2}$ in. U.H.)	2	
14	S26-2	Spring washer	2	} Smiths DF9110/00
15	D609	Speedometer cable (65 ins. long)	1	
16	E5756	TACHOMETER GEARBOX	1	} TR6R, T120R,
17	E5153	Securing screw	1	
18	E5156	Bush	1	
19	E5155	Flanged bush	1	
20	E5157	Driving gear	1	
21	E5759	End cap	1	
22	E6300	"O" ring	1	
23	E5578	Driven gear	1	
24	E6122	Driven gear housing	1	
25	E6299	"O" ring	1	
26	E6124	Bush	1	
27	E3309	"O" ring	1	
28	E5881	Set screw	1	
29	D578	Tachometer cable (28 in. long)	1	
30	RSM3003/01	Tachometer	1	
31	31-371-398	Spade	1	
32	D494	Circlip	1	
33	E6961	Sealing washer	1	
—	D546	Blanking plug (replaces tacho bulb holder)	1	Not illustrated

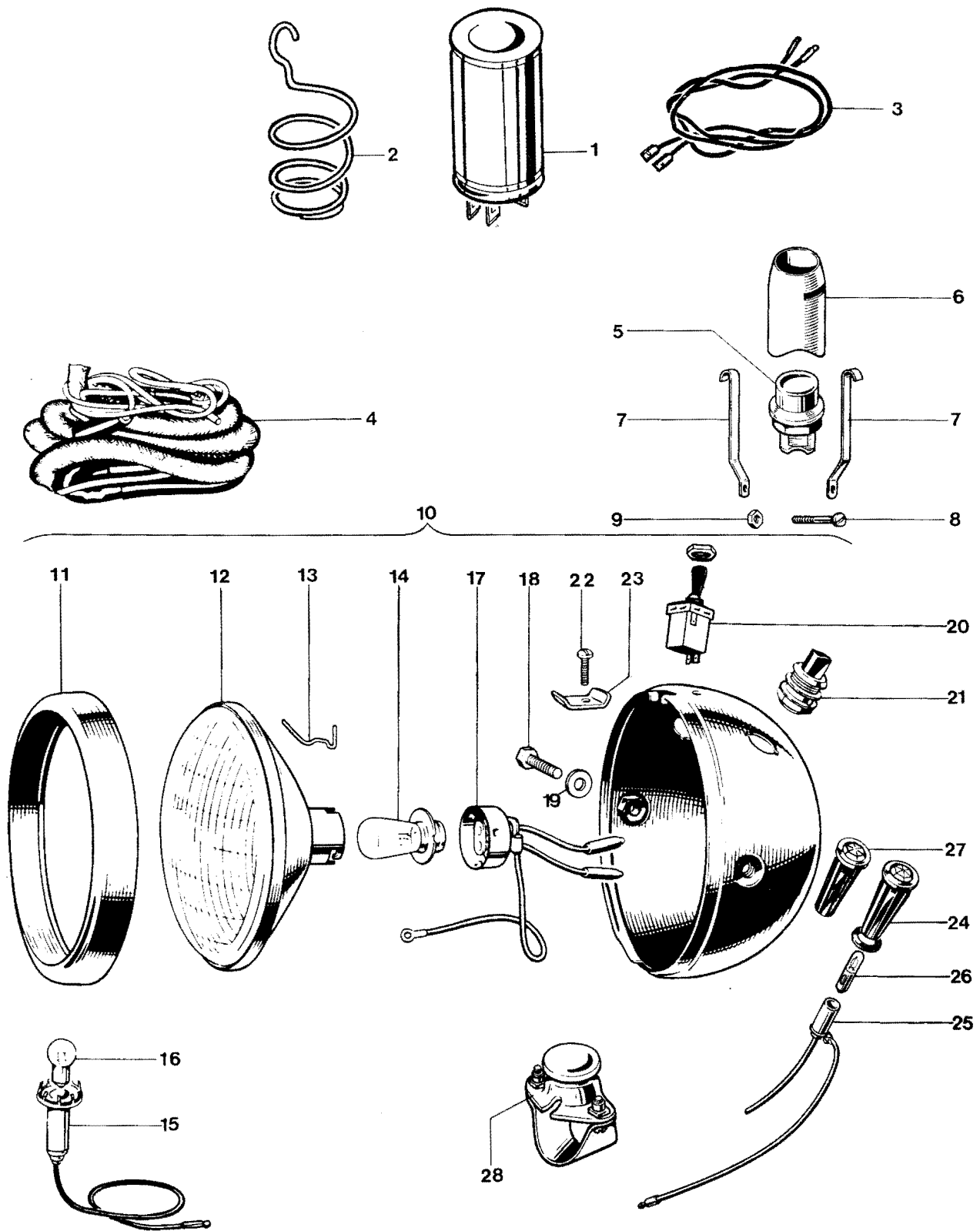

Fig. 34. IGNITION CAPACITOR AND HEADLAMP TR6C

Ref. No.	Part No.	DESCRIPTION	QUANTITY	REMARKS
IGNITION CAPACITOR AND HEADLAMP, TR6C				
1	54170009	Ignition capacitor (type 2MC)	...	Available
2	54483156	Capacitor mounting spring	...	Available
-	F9274	Cap, wiring harness terminal	...	Available
3	54953455	Sub harness—to connect capacitor	...	Available TR6R, T120R (Standard on TR6C) TR6C
4	54953440	Wiring harness	...	1
5	35835	Kill button, type 151SA	...	1
6	H2259	Cup	...	1
7	H2034	Clip	...	2
8	H687	Bolt ($\frac{3}{8}$ in. U.H.)	...	1
9	H745	Nut	...	1
10	59882	HEADLAMP ASSEMBLY, MCH 66	...	1
11	534343	Rim	...	1
12	516828	Light unit	...	1
13	504665	Fixing wire	...	6
14	446	Bulb (50/40W. Vertical Dip, Pre-focus)	...	1
15	554710	Bulbholder, pilot	...	1
16	989	Bulb (3W. M.C.C.)	...	1
17	554602	Adaptor	...	2
18	112201	Bolt	...	2
19	13749	Washer	...	2
20	35710	Lighting switch	...	1
21	31620	Dip switch	...	1
22	144921	Screw	...	1
23	534296	Plate	...	1
24	38189	Warning light, red	...	1
25	54945043	Warning bulbholder	...	1
26	281	Bulb (2W. BA75)	...	2
27	38191	Warning light, green	...	1
28	D553	Horn push, Clear Hooters No. 10	...	1

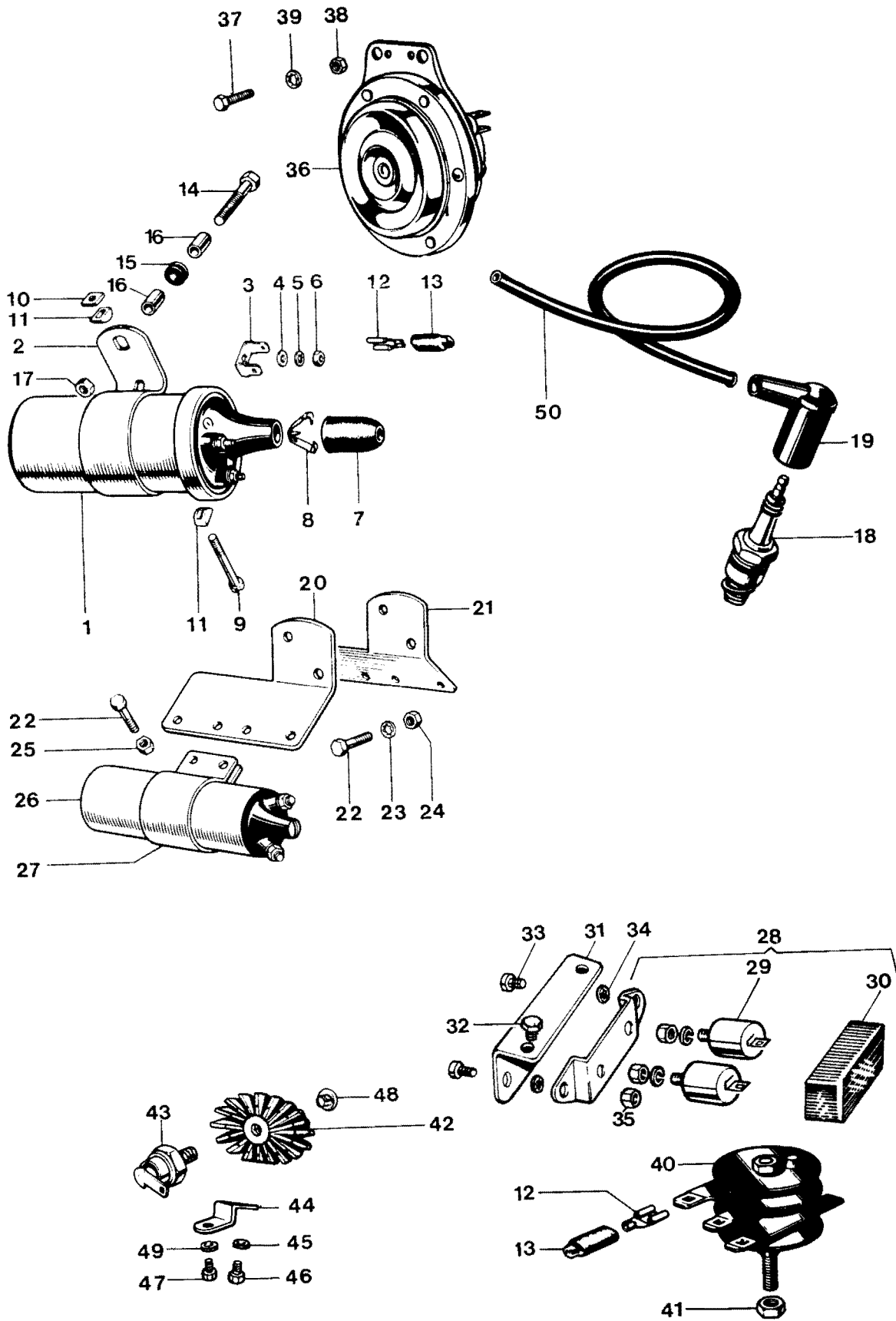

Fig. 35. IGNITION COILS, HORN, RECTIFIER AND ZENER DIODE

IGNITION COILS, HORN, RECTIFIER AND ZENER DIODE

Ref. No.	Part No.	DESCRIPTION	QUANTITY	REMARKS
1	45110	IGNITION COIL, Type MA12	2	} TR6R
2	423947	Bracket	2	
3	54190108	Lucar terminal	4	
4	131023	Plain washer (E2351)	4	
5	188330	Serrated washer (GS299)	4	
6	166043	Nut (F3799)	4	
7	421554	Rubber grommet	2	
8	421863	Cable clip	2	
9	54100776	Screw	2	
10	169160	Square nut	2	
11	422369	"D" washer	4	
12	54942078	Lucar connector	as required	} as required
13	54190042	Insulating cover	as required	
14	F4744	Bolt (1 $\frac{5}{16}$ in. U.H.)	2	} T120R
15	F5466	Rubber grommet	2	
16	F4366	Distance piece	4	
17	E3290	Self locking nut	2	
18	—	Sparking plug (Champion N3)	2	
19	D262	Plug cover	2	
20	F6943	Left coil bracket	1	
21	F6944	Right coil bracket	1	
22	F1369	Bolt ($\frac{5}{8}$ in. U.H.)	4	
23	E1612	Serrated washer	2	
24	S1-40	Nut	2	
25	F879	Nut	6	
26	E6388	Ignition coil, Siba 32,000	2	} T120R
27	E6389	Clip, Siba 32,000/1	2	
28	47638	CONDENSER PACK 2CP	1	}
29	54418527	Condenser	2	
30	54418528	Cover	1	
31	F8082	Condenser pack bracket	1	
32	F4771	Bolt, bracket to frame	2	
33	S683	Bolt, pack to bracket	2	
34	GS299	Shakeproof washer	2	
35	F3799	Nut	2	
36	70197	Horn, type 6H	1	
37	F4771	Screw ($\frac{3}{8}$ in. U.H.)	2	
38	F3799	Nut	3	
39	GS299	Serrated washer	3	}
40	49072	Rectifier, type 2DS 506	1	
41	F5338	Nut (156 596)	1	
42	H2237	Heat sink	1	
43	49345	Zener diode	1	
44	H2236	Bracket	1	
45	526-2	Washer	1	
46	14-6102/001	Bolt (bracket to heat sink)	1	
47	14-0113/001	Bolt (bracket to fork)	1	
48	H2275	Plug heat sink	1	
49	S26-3	Washer	1	
50	842183	High tension lead	1	

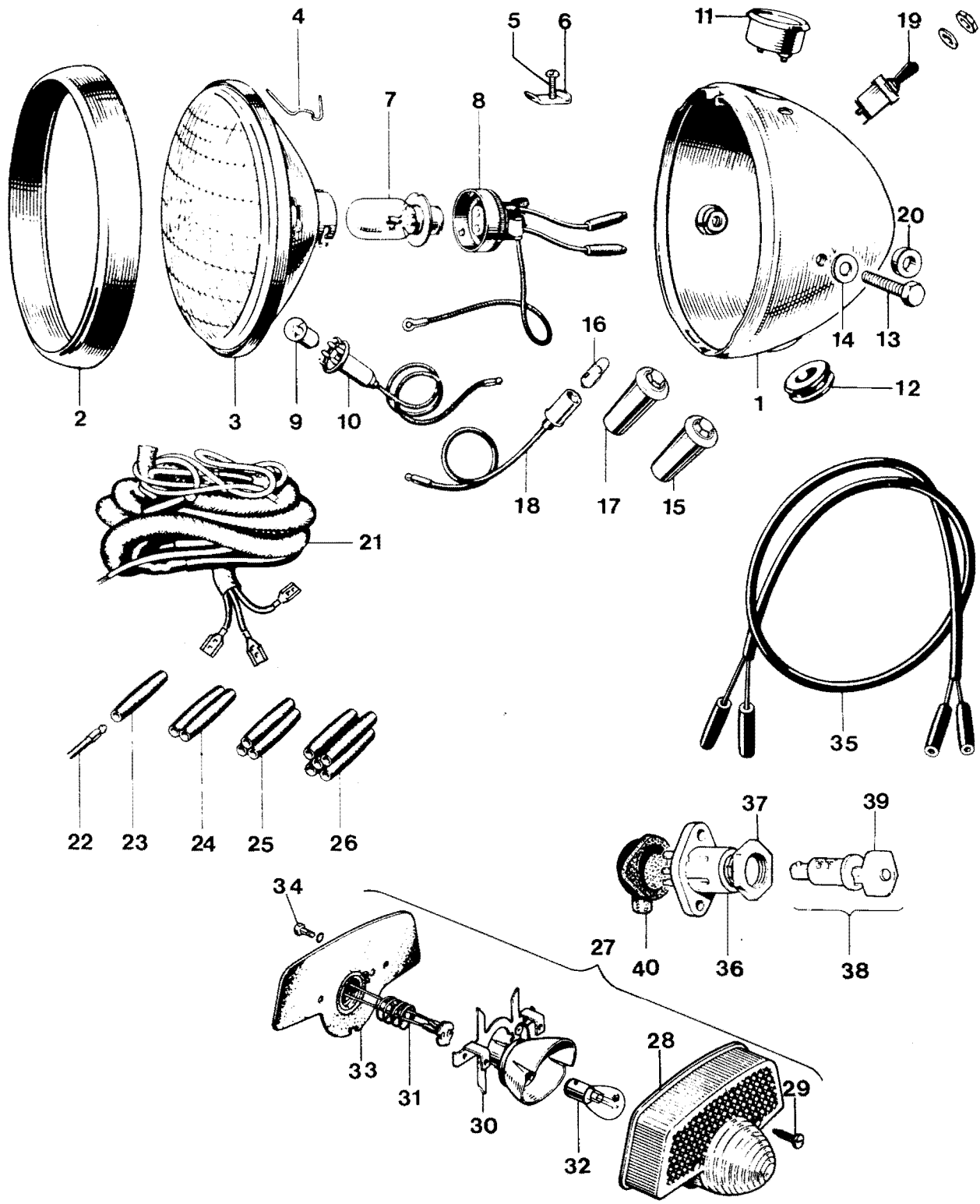

Fig. 36. HEADLAMP, WIRING HARNESS, SWITCHES AND TAIL LAMP

HEADLAMP, WIRING HARNESS, SWITCHES AND TAIL LAMP

1	59883	HEADLAMP COMPLETE TYPE SS700P	1	
1	54523508	Shell only	1	
2	553248	Rim...	1	
3	516798	Light unit	1	
4	504665	Fixing wire...	6	
5	144921	Screw	1	
6	534296	Plate	1	
7	446	Bulb (50/40 W. Vert dip. Pre-focus)	1	
8	54520540	Main bulbholder c/w leads	1	
9	989	Bulb (3W. M.C.C.)	1	
10	554710	Pilot bulbholder	1	
11	36403	Ammeter, type 2AR	1	
12	862217	Grommet	1	
13	112201	Bolt	2	
14	137498	Plain washer	2	
15	38189	Warning light body (Red)	1	
16	281	Bulb (2W. BA7S)	1	
17	38191	Warning light body (Green)	1	
18	54945043	Warning bulbholder	1	
19	35710	Lighting switch	1	
20	H1932	Distance piece	2	
21	54953443	Wiring harness	1	
22	900269	Snap connector terminal		as required
23	900288	Single snap connector		as required
24	850641	Double snap connector		as required
25	850844	Triple snap connector		as required
26	850832	Quintuple snap connector		as required
27	53973	STOP AND TAIL LAMP, Type L679	1	} TR6R, T120R
28	54572932	Lens	1	
29	572289	Screw	2	
30	54574348	Bulb holder with reflector	1	
31	573828	Contact assembly	1	
32	380	Bulb (6/21W. Offset pin)	1	
33	54571677	Gasket	1	
34	127684	Screw	2	
35	838604	Stop and tail lamp lead	1	
36	31899	Ignition switch, type S45	1	
37	54130041	Nut	1	
38	F6981	IGNITION LOCK c/w KEYS	1	
39	D662	Ignition key (state serial number)		as required
40	H2262	Ignition switch cover	1	